

BDA Installation Sheet 485855-001

The Broadband Telecommunications Drop Amplifier (BDA) is a two-way, 1 GHz amplifier designed for customer-premise amplification to compensate for long drops and excessive splitting losses.

Single-output (BDA-*1), two-output (BDA-*2), and four-output (BDA-*4) versions enable internal or external splitting.

Additional features include:

- Gallium Arsenide technology for improved distortion and noise performance
- Built-in diplex filters for two-way operation
- Local or remote powering by a UL approved, current limited, 120-volt or 220-volt, ac-to-dc power supply
- Gain is consistent with typical house drop requirements
- A weather seal and protective coating for indoor or outdoor applications
- -6 kV surge resistance

Figure 1 illustrates the BDA-S1 drop amplifier:

Figure 1
BDA-S1 drop amplifier

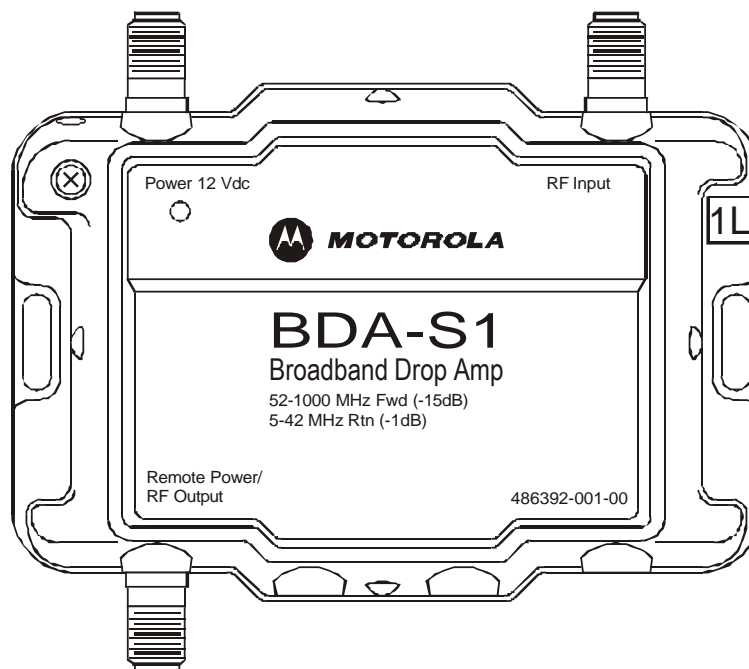
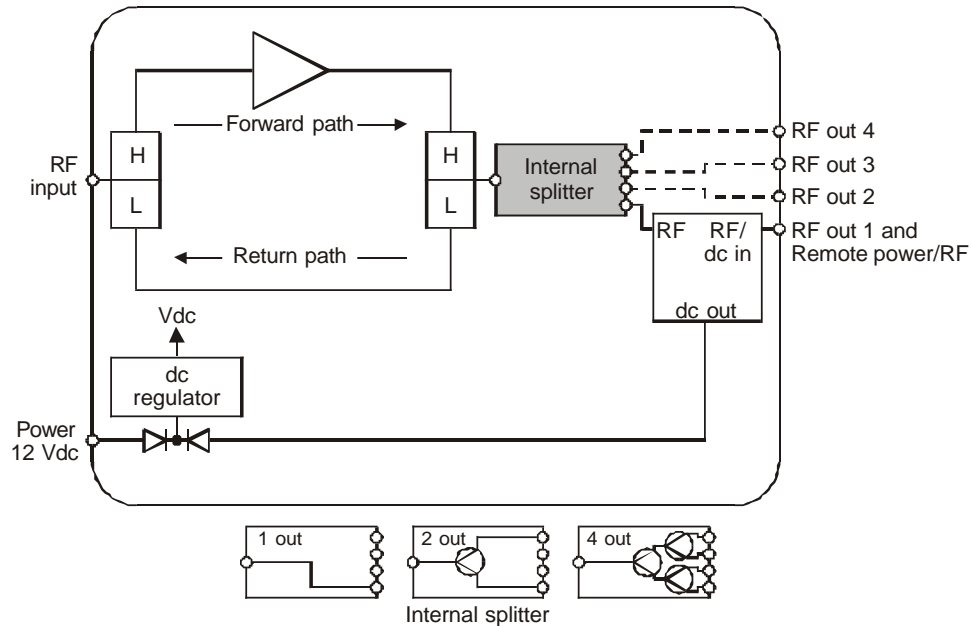

Figure 2 illustrates a functional block diagram of the BDA-^{**} drop amplifier:

Figure 2
Block diagram



Document Conventions

Before you begin using the BDA-^{**} familiarize yourself with the stylistic conventions used in this installation sheet:

SMALL CAPS Denotes silk screening on the equipment, typically representing input/output (I/O) and power supply connections

(asterisk) Indicates that more than one version of the same model number exists and the information applies to all models; when the information applies to a specific model, the complete model number is given

Before You Begin

Unpack the unit carefully and verify that you have received:

BDA-** 1 GHz drop amplifier

BDPS* Power supply – included with models BDA-**/PS

Optional

Accessory:

BDP-100/PI 1 GHz indoor power inserter for remote powering of the amplifier

Installation

To install a BDA-** drop amplifier using local power:

- 1 Remove and discard the port thread protectors.
- 2 Connect the amplifier RF output ports (RF OUTPUT 1, 2, 3, 4) to your televisions or set-top terminals using coaxial cable terminated with F-type connectors.
- 3 Terminate all unused ports with 75 ohms for optimum RF performance.
- 4 Connect the coaxial cable-in source to the RF INPUT port of the amplifier.
- 5 Connect one end of the coaxial cable to the ac adapter and the other end to the POWER 12 VDC connector on the amplifier.
- 6 Plug the ac adapter into the wall outlet. The LED on the BDA should be lit to indicate that the unit is receiving 12 Vdc.

Figure 3 illustrates a local-power installation:

Figure 3
Local-power installation

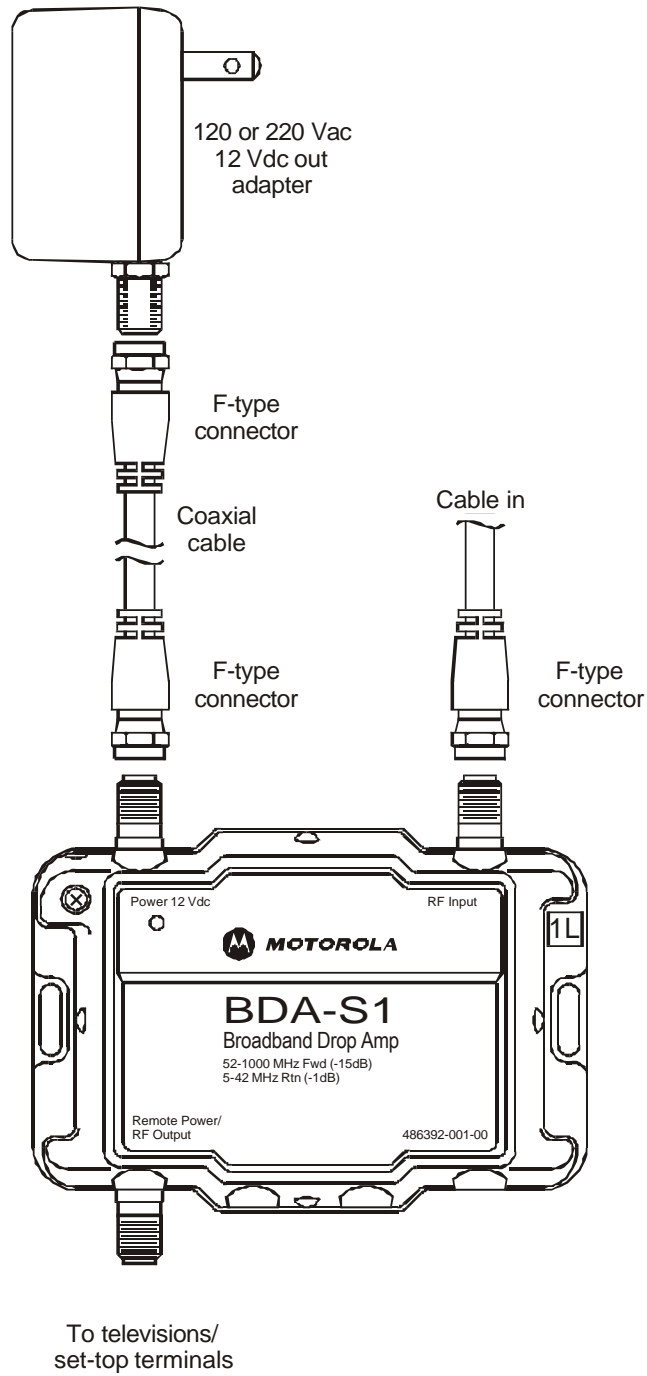

You can locate the BDA-** remotely in the basement or attic and power it from an ac outlet near the television. For best signal quality, install the BDA-** as close to the cable entrance as possible. Use the power inserter to send power to the amplifier through the coaxial cable attached to REMOTE POWER/RF port 1 on the amplifier.

To install a BDA-** drop amplifier using remote power:

- 1 Connect a coaxial cable from the REMOTE POWER/RF OUTPUT port of the amplifier to the RF-PWR port of the BDP-100/PI power inserter.
- 2 Connect the RF OUT port of the power inserter to your television or set-top terminal using a coaxial cable.
- 3 If you have a two or four output amplifier, connect the additional televisions or set-top terminals to the remaining output ports on the amplifier using coaxial cable.
- 4 Terminate all unused ports with 75 ohms for optimum RF performance.
- 5 Connect the coaxial cable-in source to the RF INPUT port of the amplifier.
- 6 Connect a coaxial cable from the ac adapter to the PWR IN port of the power inserter.
- 7 Plug the ac adapter into the wall outlet.

The POWER 12 VDC port on the amplifier remains non-terminated.

Figure 4 illustrates a remote-power installation:

Figure 4
Remote-power installation

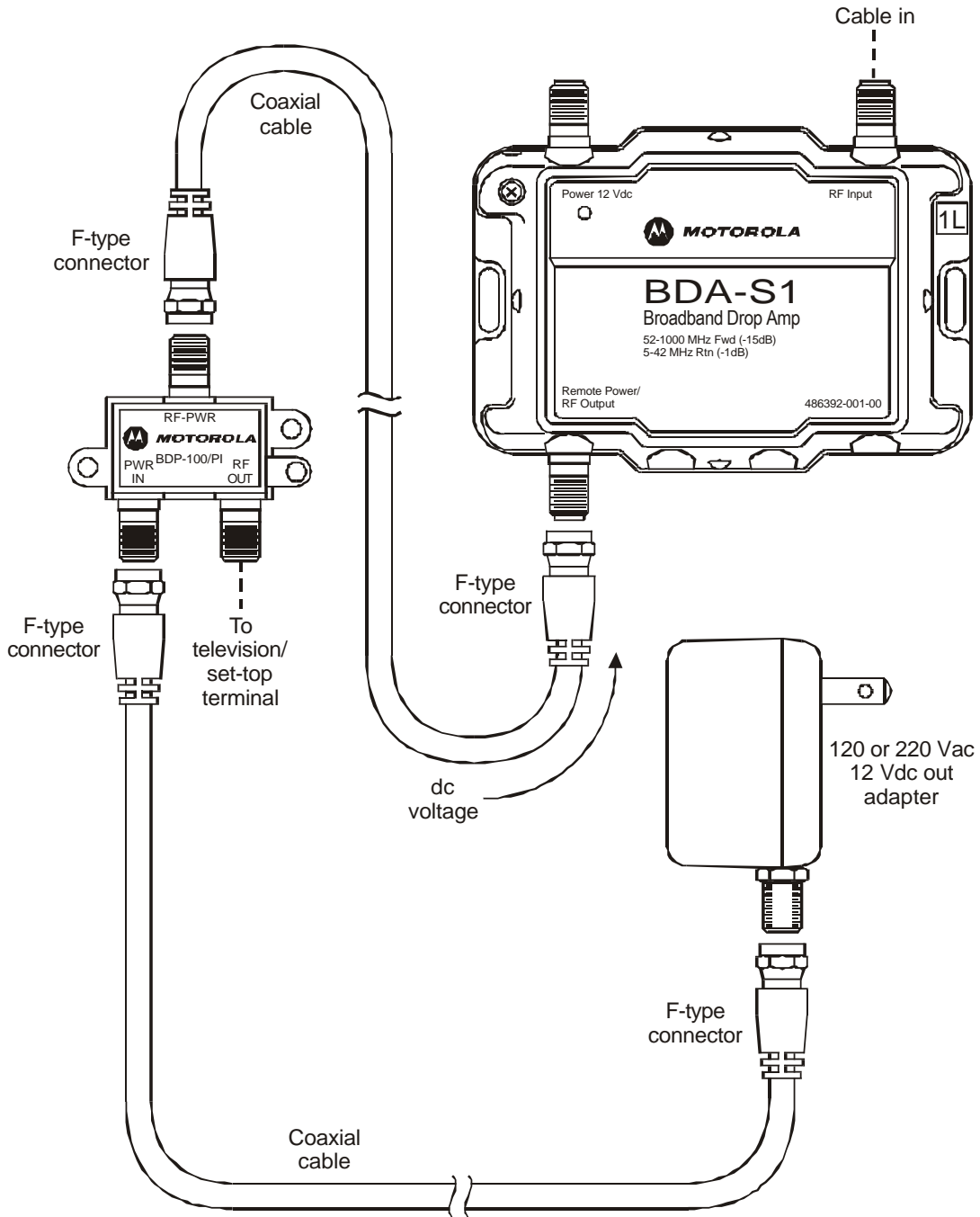

Specifications

The following specifications apply to the BDA-S* drop amplifier:

Forward Path	Value
Passband (MHz)	52 through 1000
Gain (dB)	
BDA-S1	14.0 minimum, 15.0 nominal
BDA-S2	10.2 minimum, 11.0 nominal
BDA-S4	6.4 minimum, 7.0 nominal
Input return loss (dB)	18.0 minimum, 23.0 nominal
Output return loss (dB)	18.0 minimum, 23.0 nominal
Flatness (dB)	±0.8 maximum
Noise figure (dB)	2.5 dB nominal, 3.0 maximum
Return Path	
Passband (MHz)	5 through 42
Insertion loss (dB)	
BDA-S1	-1.6 maximum, -1.0 nominal
BDA-S2	-4.8 maximum, -4.4 nominal
BDA-S4	-8.5 maximum, -8.0 nominal
Input return loss (dB)	18.0 minimum, 25.0 nominal
Output return loss (dB)	18.0 minimum, 25.0 nominal
General	
ac power supply input voltage	120 or 220 Vac nominal – depending on model
dc amplifier input voltage	12 Vdc nominal
Power consumption	3 watts
Operating temperature	-40°F through +140°F (-40°C through +60°C)
Housing dimensions	4.0 × 4.9 × 1.1 inches (102 × 124 × 28 mm)
Weight	1.1 lb. (0.5 kg.)

If You Need Help

If you need assistance while working with the BDA-**, contact the Motorola Technical Response Center (TRC):

- Inside the U.S.: 1-888-944-HELP (1-888-944-4357)
- Outside the U.S.: 215-323-0044
- Online: <http://broadband.motorola.com/noflash/websupport.html>.

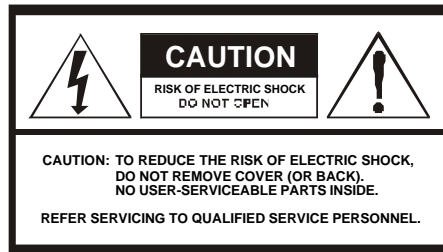

The TRC is open from 8:00 AM to 2:00 AM Eastern Time, Monday through Friday and 10:00 AM to 5:00 PM Eastern Time, Saturday. When the TRC is closed, emergency service *only* is available on a call-back basis. Web Support offers a searchable solutions database, technical documentation, and low priority issue creation/tracking 24 hours per day, 7 days per week.



Caution

These servicing instructions are for use by qualified personnel only. To reduce the risk of electrical shock, do not perform any servicing other than that contained in the Installation and Troubleshooting Instructions unless you are qualified to do so. Refer all servicing to qualified service personnel.

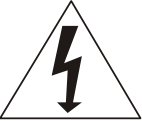
Special Symbols That Might Appear on the Equipment

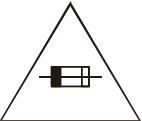
	This symbol indicates that dangerous voltage levels are present within the equipment. These voltages are not insulated and may be of sufficient strength to cause serious bodily injury when touched. The symbol may also appear on schematics.
	The exclamation point, within an equilateral triangle, is intended to alert the user to the presence of important installation, servicing, and operating instructions in the documents accompanying the equipment.
	For continued protection against fire, replace all fuses only with fuses having the same electrical ratings marked at the location of the fuse.

	This equipment operates over the marked Voltage and Frequency range without requiring manual setting of any selector switches.
-------------------------------------------------------------------------------------	--------------------------------------------------------------------------------------------------------------------------------

FCC Compliance

This equipment has been tested and found to comply with the limits for a B digital device, pursuant to Part 15 of the FCC Rules. These limits are designed to provide reasonable protection against harmful interference when the equipment is operated in a residential environment. This equipment generates, uses, and can radiate radio frequency energy and, if not installed and used in accordance with the instructions, may cause harmful interference to radio communications. However, there is no guarantee that interference will not occur in a particular installation. If this equipment does cause harmful interference to radio or television reception, which can be determined by turning the equipment off and on, the user is encouraged to try to correct the interference by one of the following measures:

- Re-orient or relocate the receiving antenna
- Increase the separation between the equipment and receiver
- Connect the equipment into an outlet on a circuit different from that to which the receiver is connected.
- Consult the dealer or an experienced radio/TV technician for help.

Changes or modification not expressly approved by the party responsible for compliance could void the user's authority to operate the equipment.

Canadian Compliance

This Class B digital apparatus meets all requirements of the Canadian Interference-Causing Equipment Regulations.
Cet appareil numérique de la classe B est conforme ? la norme NMB-003 du Canada.

FCC Declaration of Conformity

According to 47 CFR, Parts 2 and 15 for Class B Personal Computers and Peripherals; and/or CPU Boards and Power Supplies used with Class B Personal Computers, Motorola, Inc., 6450 Sequence Drive, San Diego, CA 92121, 1-800-225-9446 or 101 Tournament Drive, Horsham, PA 19044, 1-800-523-6678, declares under sole responsibility that the product identifies with 47 CFR Part 2 and 15 of the FCC Rules as a Class B digital device. Each product marketed is identical to the representative unit tested and founded to be compliant with the standards. Records maintained continue to reflect the equipment being produced can be expected to be within the variation accepted, due to quantity production and testing on a statistical basis as required by 47 CFR 2.909. Operation is subject to the following condition: This device must accept any interference received, including interference that may cause undesired operation. The above named party is responsible for ensuring that the equipment complies with the standards of 47 CFR, Paragraphs 15.107 to 15.109

International Declaration of Conformity

We
Motorola, Inc.
101 Tournament Drive
Horsham, PA 19044, U.S.A.

declare under our sole responsibility that the
Broadband Drop Amp Model BDA -**
to which this declaration relates is in conformity with one or more of the following standards:

EMC Standards

EN550	EN55020	EN50083-2	CISPR-13	CISPR20
-------	---------	-----------	----------	---------

13

Safety Standards

EN609	IEC 60950 + A1: 1992 + A2: 1993 + A3: 1995 + A4: 1996
-------	-------------------------------------------------------

50

following the provisions of the Directive(s) of the Council of the European Union:

Copyright © 2003 by Motorola, Inc.

All rights reserved. No part of this publication may be reproduced in any form or by any means or used to make any derivative work (such as translation, transformation or adaptation) without written permission from Motorola, Inc.

Motorola reserves the right to revise this publication and to make changes in content from time to time without obligation on the part of Motorola to provide notification of such revision or change. Motorola provides this guide without warranty of any kind, either implied or expressed, including, but not limited to, the implied warranties of merchantability and fitness for a particular purpose. Motorola may make improvements or changes in the product(s) described in this manual at any time.

MOTOROLA, and the Stylized M Logo are registered in the US Patent & Trademark Office. All other product or service names are the property of their respective owners. © Motorola, Inc. 2003.

485855-001 All rights reserved.
9/03 No part of the contents of this manual may be reproduced or transmitted in any form or by any means without the written permission of the publisher.