



motorola **W510**

User's Guide

HELLOMOTO

Introducing your new Motorola W510 GSM wireless phone. Here's a quick anatomy lesson.

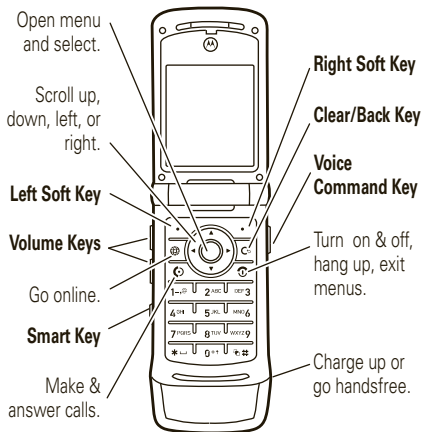

To change your home screen shortcuts and your main menu appearance, see page 48.

Home Screen

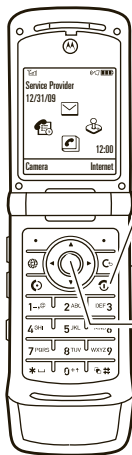

1 Press and hold the **Power Key**  for a few seconds, or until the display lights up, to turn on your phone.

2 Press the **Center Key**  to open the **Main Menu**.

Main Menu

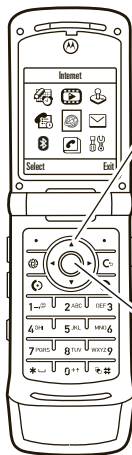

3 Press the **Navigation Key** **up, down, left, or right** () to highlight a menu feature.

4 Press the **Center Key**  to select it.

Motorola, Inc.
Consumer Advocacy Office
1307 East Algonquin Road
Schaumburg, IL 60196

www.hellomoto.com

1-800-331-6456 (United States)

1-888-390-6456 (TTY/TDD United States for hearing impaired)

1-800-461-4575 (Canada)

Certain mobile phone features are dependent on the capabilities and settings of your service provider's network. Additionally, certain features may not be activated by your service provider, and/or the provider's network settings may limit the feature's functionality. Always contact your service provider about feature availability and functionality. All features, functionality, and other product specifications, as well as the information contained in this user's guide are based upon the latest available information and are believed to be accurate at the time of printing. Motorola reserves the right to change or modify any information or specifications without notice or obligation.

MOTOROLA and the Stylized M Logo are registered in the US Patent & Trademark Office. All other product or service names are the property of their respective owners. The Bluetooth trademarks are owned by their proprietor and used by Motorola, Inc. under license. Microsoft, Windows and Windows Me are registered trademarks of Microsoft Corporation; and Windows XP is a trademark of Microsoft Corporation.

© Motorola, Inc. 2008.

Caution: Changes or modifications made in the radio phone, not expressly approved by Motorola, will void the user's authority to operate the equipment.

Software Copyright Notice

The Motorola products described in this manual may include copyrighted Motorola and third-party software stored in semiconductor memories or other media. Laws in the United States and other countries preserve for Motorola and third-party software providers certain exclusive rights for copyrighted software, such as the exclusive rights to distribute or reproduce the copyrighted software. Accordingly, any copyrighted software contained in the Motorola products may not be modified, reverse-engineered, distributed, or reproduced in any manner to the extent allowed by law. Furthermore, the purchase of the Motorola products shall not be deemed to grant either directly or by implication, estoppel, or otherwise, any license under the copyrights, patents, or patent applications of Motorola or any third-party software provider, except for the normal, non-exclusive, royalty-free license to use that arises by operation of law in the sale of a product.

Manual Number: 6809519A95-A

contents

menu map	6	videos	24	customize	44
Use and Care	8	text messages	26	talking phone	44
essentials	9	memory card	28	ring style	44
about this guide	9	cable connections	29	time & date	45
SIM card	10	phone updates	31	wallpaper	46
battery	10	basics	32	screen saver	46
turn it on & off	12	display	32	themes	46
make a call	13	text entry	35	display appearance	47
answer a call	13	volume	39	shortcuts and main menu ..	48
store a phone number	13	navigation key	39	answer options	49
call a stored phone number	14	voice commands	39	calls	50
your phone number	14	external display	42	turn off a call alert	50
main attractions	15	handsfree speaker	42	delay answering	50
Bluetooth® wireless		codes & passwords	42	call history	50
connections	15	lock & unlock phone	43	redial	52
digital audio player	18	lock & unlock external keys	43	return a call	52
photos	20			caller ID	53

emergency calls	53	Warranty	95
voicemail	54	Hearing Aids	99
other features	55	WHO Information	100
advanced calling	55	Registration	100
contacts	59	Export Law	101
messages	65	Recycling Information	101
personalizing	68	Perchlorate Label	102
call times & costs	70	Privacy and Data Security . .	103
handsfree	71	Driving Safety	104
data calls	71	index	106
network	73		
personal organizer	74		
security	77		
fun & games	78		
service & repairs	82		
SAR Data	83		
EU Conformance	85		
Safety Information	88		
Industry Canada Notice	93		
FCC Notice	94		

menu map

main menu



Tools

- SIM Applications *
- Calculator
- Calendar
- Alarm Clock
- Dialing Services
 - Fixed Dial *
 - Voice Dial
 - Service Dial *
 - Quick Dial
- World Clock



Multimedia/Sounds

- Themes
- Voice Records
- Camera
- Video Camera
- Graphics
- Audio
- Videos



Games & Apps



Call History

- (press the  or  to scroll through the call lists)



Internet *

- Browser
- Browser Setup
- Web Sessions *



Messages

- Create Message
- Message Inbox
- Templates
- Voicemail
- Email Msgs
- Outbox
- Drafts
- Browser Msgs
- Info Services*



Bluetooth Link



Contacts



Settings



- (see next page)

* optional features

This is the standard main menu layout.

Your phone's menu may be different.

To change your home screen shortcuts and your main menu appearance, see page 48.

Tip: Press  to exit the current menu, or  to exit all menus.

settings menu



Personalize

- Home Screen
- Main Menu
- Voice Dial Setup
- Skin
- Greeting
- Wallpaper
- Screen Saver
- Sound Settings



Ring Styles

- Style
- *(style)* Detail



Connection

- USB Settings
- Motosync



Call Forward *

- Voice Calls*
- Fax Calls*
- Data Calls*
- Cancel All
- Forward Status



In-Call Setup

- In-Call Timer
- My Caller ID
- Answer Options
- Call Waiting



Initial Setup

- Time and Date
- Speed Dial
- Display Timeout
- Backlight
- TTY Setup *
- Scroll
- Text Marquee
- Language
- Brightness
- DTMF
- Master Reset
- Master Clear



Phone Status

- My Tel. Numbers
- Active Line *
- Battery Meter
- Download Location
- Storage Devices
- Software Update *
- Other Information



Headset

- Auto Answer
- Voice Dial



Car Settings

- Auto Answer
- Auto Handsfree
- Power-Off Delay
- Charger Time



Airplane Mode

- Airplane Mode
- Prompt at Power Up



Network

- New Network
- Network Setup
- Available Networks
- Service Tone *
- Call Drop Tone



Security

- Phone Lock
- External Key Lock
- Lock Application
- Fixed Dial *
- Restrict Calls *
- Call Barring *
- SIM PIN
- New Passwords
- Certificate Mgmt *



Java™ Settings

- Java System
- Delete All Apps
- App Vibration
- App Volume

* optional features

Use and Care

To care for your Motorola phone, please keep it away from:



liquids of any kind

Don't expose your phone to water, rain, extreme humidity, sweat, or other moisture. If it does get wet, don't try to accelerate drying with the use of an oven or dryer, as this may damage the phone.



extreme heat or cold

Avoid temperatures below 0°C/32°F or above 45°C/113°F.



microwaves

Don't try to dry your phone in a microwave oven.



dust and dirt

Don't expose your phone to dust, dirt, sand, food, or other inappropriate materials.



cleaning solutions

To clean your phone, use only a dry soft cloth. Don't use alcohol or other cleaning solutions.



the ground

Don't drop your phone.

essentials

CAUTION: Before using the phone for the first time, read the *Important Safety and Legal Information* included in the gray-edged pages at the back of this guide.





about this guide

This guide shows how to open a menu feature as follows:

Find it:  >  Messages > Create Message

This means that, from the home screen:

1 Press the *center key*  to open the menu.

- 2 Press the *navigation key*  to scroll to  **Messages**, and press the *center key*  to select it.
- 3 Press the navigation key  to scroll to **Create Message**, and press the center key  to select it.

symbols



This means a feature is network, SIM card, or subscription dependent and may not be available in all areas. Contact your service provider for more information.



This means a feature requires an optional accessory.

SIM card

Caution: Don't bend or scratch your SIM card. Keep it away from static electricity, water, and dirt.

Your *Subscriber Identity Module* (SIM) card contains personal information like your phone number and contacts entries.

To insert and use a **memory card**, see page 28.

Turn off your phone and remove your battery before you install or remove a SIM card.

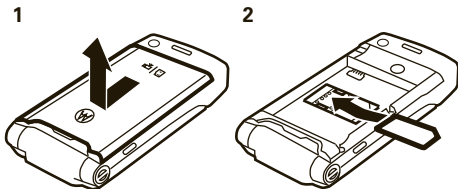

battery

battery installation

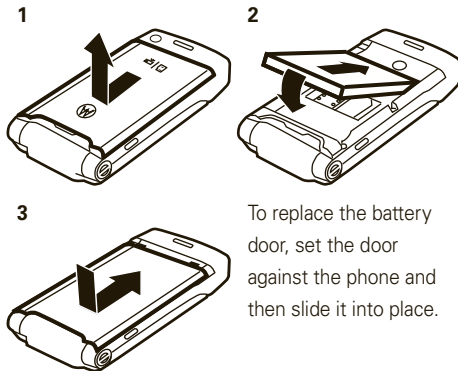

To replace the battery door, set the door against the phone and then slide it into place.

battery charging

New batteries are not fully charged.

Plug the battery charger into your phone and an electrical outlet.

Your phone might take several

seconds to start

charging the battery. When finished, your display shows **Charge Complete**.

Tip: Relax, you can't overcharge your battery. It will perform best after you fully charge and discharge it a few times.

You can charge your battery by connecting a **cable** from your phone's mini-USB port to a USB port on a computer. Both your phone and the

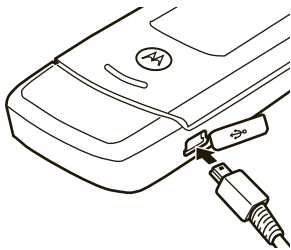

computer must be turned on, and your computer must have the correct software drivers installed. Cables and software drivers are available in Motorola Original data kits, sold separately.

If your battery is completely dead and you plug in a **cable** to charge it, your keypad and display might not light up. Your battery will still charge.

battery tips

Battery life depends on the network, signal strength, temperature, features, and accessories you use.

- Always use Motorola Original batteries and chargers. The warranty does not cover damage caused by non-Motorola batteries and/or chargers.
- New batteries or batteries stored for a long time may take more time to charge.



- When charging your battery, keep it near room temperature.

When storing your battery, keep it uncharged in a cool, dark, dry place.

- Never expose batteries to temperatures below -10°C (14°F) or above 45°C (113°F). Always take your phone with you when you leave your vehicle.
- It is normal for batteries to gradually wear down and require longer charging times. If you notice a change in your battery life, it is probably time to purchase a new battery.



Contact your local recycling center for proper battery disposal.

Warning: Never dispose of batteries in a fire because they may explode.

Before using your phone, read the battery safety information in the “Safety and General Information” section included in this guide.

turn it on & off

Caution: Some phones ask for your SIM card PIN code when you turn them on. If you enter an incorrect PIN code three times before the correct code, your SIM card is disabled, and your display shows **SIM Blocked**. Contact your service provider.

To turn on your phone, press and hold  for a few seconds or until the keypad or display lights up.



If prompted, enter your eight-digit SIM card PIN code and/or four-digit unlock code (for more about codes, see page 42).

To turn off your phone, press and hold  for a few seconds.

make a call

To make a call, enter a phone number and press .

To “hang up,” close the flip or press .

To use voice commands for calling, see page 39.

answer a call

To answer a call when your phone rings and/or vibrates, just open the flip or press . To “hang up,” close the flip or press .

Note: Your phone cannot receive data over an EDGE network while it is playing videos or some audio files. The EDGE  status indicator appears at the top of your display when you can receive data over an EDGE network.



store a phone number

You can store a phone number in your contacts:

Find it:  >  **Contacts**



- 1 Press **Options**, then select **Create New**.

Note: You can store new contacts in your **phone’s memory** or on your **SIM card**. Contacts on the SIM card only include a **Name** and **Number**.

- 2 Enter a name and other details for the phone number. To select a highlighted item, press the *center key* .
- 3 Press **Done** to store the number.

To **edit** or **delete** a contacts entry, see page 60.

To store an **email** address from the home screen, follow the steps above and enter the new contact’s name and **Email** information.

Shortcut: Enter a phone number in the home screen, then press **Store** to create a contact. To choose whether your phone stores these contacts in your phone's memory or on your SIM card, go back to the home screen and press  >  **Contacts**, press **Options** and select **Setup**, then select **Default Storage** and then **Phone** or **SIM Card**.

call a stored phone number



Find it:  >  **Contacts**

- 1 Scroll to the contacts entry.

Shortcut: In the contacts list, press keypad keys to enter the first letters of an entry you want.



- 2 Press  to call the entry.

Note: You can show contacts stored in your phone's memory or on your SIM card. To choose which



contacts you see, press  >  **Contacts**, then press **Options** and select **View**. You can then select **Phone & SIM Card**, **SIM Card**, or **Phone Contacts**.

To use voice commands for calling, see page 39.

your phone number

From the home screen, press *the clear key* , then , to see your number.

Tip: Want to see your phone number while you're on a call? Press **Options** and select **My Tel. Number**.

You can edit the name and phone number stored on your SIM card. From the home screen, press  , select an entry, press **View**, press **Options**, and select **Edit**. If you don't know your phone number, contact your service provider.



main attractions

You can do much more with your phone than make and receive calls!

Bluetooth® wireless connections

Your phone supports Bluetooth wireless connections. You can connect your phone with a Bluetooth headset or car kit to make handsfree calls. You can also connect your phone with a phone or computer that supports Bluetooth connections to exchange files.

Note: The use of wireless phones while driving may cause distraction. Discontinue a call if you can't concentrate on driving. Additionally, the use of wireless devices and their accessories may be

prohibited or restricted in certain areas. Always obey the laws and regulations on the use of these products.

For maximum Bluetooth security, you should always connect Bluetooth devices in a safe, private environment.

turn Bluetooth power on/off

Set Bluetooth power to be on whenever the phone is on.

Find it:  >  Bluetooth Link > Setup > Power > On

Note: To extend battery life, set Bluetooth power to **Off** when not in use. If you turn Bluetooth power **Off**, your phone will not connect to other Bluetooth devices until you turn Bluetooth power **On** and reconnect.

place phone in discovery mode

Allow an unknown Bluetooth device to discover your phone:

Find it:  >  Bluetooth Link > Find Me

use a headset or handsfree car kit

Before you try to connect your phone with a handsfree device, make sure the device is **on** and **ready** in *pairing* or *bonding* mode (see the user's guide for the device). You can connect your phone with only one device at a time.

Find it:  >  Bluetooth Link > [Add Audio Device]



Your phone lists the devices it finds within range.

- 1 Scroll to a device in the list and press the *center key* .
- 2 Press **Yes** or **OK** to connect to the device.

- 3 If necessary, enter the device passkey (such as 0000) and press **OK**.

When your phone is connected, the Bluetooth indicator  appears in the home screen.

Shortcut: When your phone's Bluetooth power is on, your phone can automatically connect to a handsfree device you have used before. Just turn on the device, or move it near the phone. If the device doesn't connect, turn it off and back on.

Tip: Want to know more about your headset or car kit? For specific information about a device, refer to the instructions that came with it.

copy files to another device

You can use a Bluetooth connection to copy a media file, contacts entry, calendar event, or Web shortcut from your phone to a computer or other device.

Note: You can't copy some copyrighted objects.

- 1 On your phone, scroll to the object that you want to copy to the other device.
- 2 Press **Options**, then select:
 - **Manage**, then **Copy** for media files.
 - **Send Contact** for contacts entries.
 - **Send** for calendar events.
- 3 Select a recognized device name, or **[Look For Devices]** to search for the device where you want to copy the file.

If your phone could not copy the file to the other device, make sure the device is **on** and **ready** in *discoverable* mode (see the user's guide for the device). Also, make sure the device is not busy with another similar Bluetooth connection.

Note: Once you connect your phone to a Bluetooth device, that device can start similar Bluetooth connections with your phone. Your display shows the

Bluetooth indicator  at the top when there is a Bluetooth connection.

receive files from another device

If you do not see the Bluetooth indicator  at the top of your phone display, turn on your phone's Bluetooth feature (see page 15).



- 1 Place your phone near the device, and send the file from the device.

If your phone and the sending device don't recognize each other, place your phone in discoverable mode so the sending device can locate it (see page 16).
- 2 Press **Accept** on your phone to accept the file from the other device.

Your phone notifies you when file transfer is complete. If necessary, press **Store** to save the file.

send files to a printer

You can use a Bluetooth connection to send a graphic, message, contacts entry, or calendar event from your phone to a printer.



Note: You cannot print message **Templates** or a contacts **Mailing List**.

- 1 On your phone, scroll to the object that you want to print, then press **Options** and select **Print**.

Tip: If you see it, you can print it. After you capture a picture in the camera, you can press **Options** and select **Print**.

- 2 If available, choose additional objects or print options.

- 3 Select a recognized printer name listed in the **Printers** menu, or [**Look For Devices**] to search for the printer where you want to print the object.

Note: If you see **Service Not Supported** when you try to print, select **Options**, then select **Manage**, then **Copy**,

then **Bluetooth** instead. Always use this option to print 4x6 photos.

digital audio player

Your phone can play and store MP3 and AAC song files. You can use a removable memory card with your phone to store more songs (see page 28).









Note: You cannot use the audio player with a USB cable connected to your phone.

Find it: > **Games & Apps** > **Digital Audio Player**

Press up or down to scroll to an option, and press the *center key* to select it:

options	
Playlists	Create or play a playlist (see page 20).

options	
Songs	Show and play individual songs. Note: Not all songs appear in the Songs list. Some songs do not have any Artist , Album , or Genre information stored, so they don't appear in those lists.
Albums	Select an album to show or play its songs.
Artists	Select an artist to show or play their songs.
Genres	Select a type of music to show or play songs.
About	Show audio player version information.

When you select a song, press the *center key*  to play , or pause , press  left for previous , or press  right for next .

Note: To change repeat , shuffle , and other settings, press **Options**.

Use the volume keys on the left side of your phone to control volume.

Your phone also has an audio player that can play songs and ring tones, but it cannot store **Artists** or other song information. **To use the audio player:**

Find it:  >  Multimedia/Sounds > Audio

Select the file you want to play.

load music files

To download songs to your phone, see page 79. To copy files between your phone and a computer, see page 30.

Note: Your phone may not play audio files that have a bit rate higher than 128 kbps. If you try to download or play one of these files, your phone might show you an

error or ask you to delete the file. Metadata information is **not** supported for **MP4** formatted files.

playlists



To create a playlist:

Find it:  >  Games & Apps > Digital Audio Player
> Playlists > [New Playlist]

- 1 Enter a name for the play list and press **Done**. Your phone shows a list of song titles.
- 2 Press the *center key*  to select songs for the playlist.
- 3 Press **Done** to store the list. Your phone shows the songs in the playlist.
- 4 Press **Done** to store the list.

To reorder songs on a playlist:

Find it:  >  Games & Apps > Digital Audio Player
> Playlists

- 1 Scroll to a playlist.
- 2 Press **Options**.
- 3 Select **Reorder Playlist**.
- 4 Press the *center key*  to select a song, then press  to move it up or down in the order. When you have it in the right spot, press **Done**.

To listen to a playlist:

Find it:  >  Games & Apps > Digital Audio Player
> Playlists

- 1 Scroll to the playlist.
- 2 Press play .

photos

Note: Java games or applications will close and end when you open the camera.

take & store or send photos

Your camera lens is on the back of your phone when the phone is open. **To get the clearest pictures, wipe the lens clean with a dry cloth before you take a picture.**

To take a photo:

Find it:  >  Multimedia/Sounds > Camera

You see the camera viewfinder:

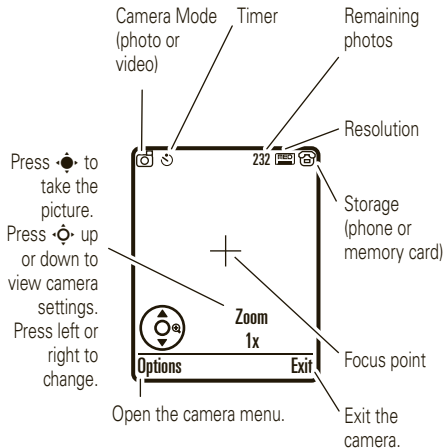

- 1 Press the *center key*  to take the photo.
- 2 Press **Options** to store the photo.

or

Press **Options**, then select **Print**, to print the picture over a Bluetooth® connection (see page 18).

or

Press **Send** to send the photo in a message.

Your phone might tell you that this is a **Multimedia Msg**, because it has a picture in it. Some other phones or networks do not support picture messages. Press **Yes** to send the message.

or

Press  to discard the photo and return to the active viewfinder.

Before you capture the photo, you can press **Options** to open the camera menu:

options	
View Phone Album	See stored graphics in the Phone Album.

options	
Go To Pictures	See stored graphics and photos.
Go To Video Mode	Switch to the video camera.
Auto-Timed Capture	Set a timer for the camera to take a photo.
Camera Setup	Open the setup menu to adjust photo settings.
Switch Storage Device	Choose to store graphics on your phone or a memory card. 
Free Space	See how much memory remains. Note: Your service provider may store some content in user memory before you receive the phone.

self portrait

If you close your phone while the viewfinder is active, the external display shows the image. Press the volume keys to zoom, or press the *smart key* to capture and store the image.

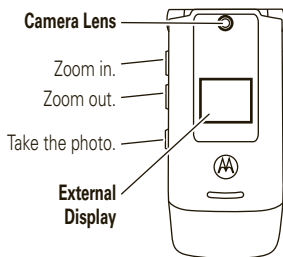

When your phone is closed, it automatically stores the photos you take. To change where it stores the photos, see **Switch Storage Device** on page 22.

see stored photos

Find it:  >  Multimedia/Sounds
> Graphics > *graphic name*

To delete a graphic:

- 1 Select the graphic in the list and press **Options**.
- 2 Select **Manage**, then select **Delete**.

To copy or move a graphic from your memory card () to phone memory ():



- 1 Select the graphic in the list and press **Options**.
- 2 Select **Manage**, then select **Copy** or **Move**.
- 3 Select **Memory Card**.

Note: You cannot copy or move some copyrighted files.

Tip: After you open a graphic, you can press **Options** and select **View Full Screen** to see the graphic at the full display size. Press any key to return to the regular view.

send a stored photo in a message

Find it:  >  Messages > Create Message
> New Message



- 1 Press **Options**, then select **Add Media**.
- 2 Select **Picture**.
- 3 Scroll to the graphic you want and press **Add Media**.
- 4 Enter the message text and press **Send To**.
- 5 Scroll to a recipient address and press the *center key* .
- 6 Press **Send** to send the message.



Your phone might tell you that this is a **Multimedia Msg**, because it has a graphic in it. Some other phones or networks do not support graphic messages. Press **Yes** to send the message.

videos

Tip: Did you know your phone allows *video streaming*? If you go to a Web site that has videos, your phone can play the videos in your browser without downloading them onto your phone.

Note: Java games or applications will close and end when you open the camera.

record video clips

Your camera lens is on the back of your phone, when your phone is open. **To get the clearest videos, wipe the lens clean with a dry cloth before you capture a video.**

To record a video clip:

Find it:  >  Multimedia/Sounds > Video Camera

You see the video viewfinder:

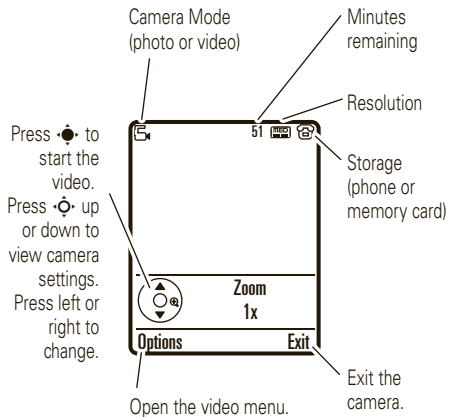

Note: The number of minutes remaining is an estimate.

Tip: If you want to send your video in a message, the video length must be set to **MMS**. To set length, press **Options** and select **Video Camera Setup**, then select **Video Length**.

- 1 Press the *center key* to start recording the video.
- 2 Press **Stop** to stop recording the video.
- 3 Press **Options** to store or discard the video.

or

Press **Send**, then select **Send** to send the video in a message.



Enter text and press **Send To**, then scroll to a recipient address and press the *center key* to select it. Press **Options** to enter a new number. To send the message, press **Send**.

Note: Some other phones or networks do not support messages with videos.

or

Press **Cancel** to discard the video and return to the active viewfinder.

play stored video clips

Find it:  >  Multimedia/Sounds > Videos
> *video name*

To delete a file:

- 1 Select the file in the list and press **Options**.
- 2 Select **Manage**, then select **Delete**.

To copy or move a file from your memory card () to your phone memory ():



- 1 Select the file in the list and press **Options**.
- 2 Select **Manage**, then select **Copy** or **Move**.
- 3 Select **Memory Card**.

Note: You cannot copy or move some copyrighted files.

Tip: While a video is playing, you can press **Options** and select **Play Full Screen** to see the video at the full display size. Press any key to return to the regular view.

text messages

To create a group mailing list, see page 63. For more message features, see page 65.

send a text message

A text message can contain text and graphics, audio, or other media objects. You can add  multiple pages to a message, and you can put text and media objects on each page. You can send a message to other compatible phones or to email addresses.

Find it:  >  Messages > Create Message > New Message

- 1 Press keypad keys to enter text on the page (for details about text entry, see page 35).

To insert a **graphic, audio file, or other object** on the page, press **Options** and select **Add Media**. Select the file type and the file.

To insert **another page** in the message, enter text or objects on the current page, press **Options**

and select **Add Media**, then select **New Page**. You can enter more text and objects on the new page.

- 2 When you finish the message, press **Send To**.
- 3 Scroll to a recipient and press the *center key* . Repeat to add other recipients.

To enter a **new** number or email address, press **Options** and select **Enter Number** or **Enter Email**.

- 4 Before you send a message, you can press **Options** to choose **Save to Drafts**, **Cancel Message**, or open **Sending Options** (such as message **Subject** or **CC** addresses).
- 5 To **send** the message, press **Send**.

Your phone might tell you that this is a **Multimedia Msg**, if it has multiple pages or media objects in it. Some other phones or networks do not support multimedia messages. Press **Yes** to send the message.

receive a text message

When you receive a message, your phone plays an alert, and the display shows **New Message** with a message indicator, such as . Press **Read** to open the message.



To see all of your text messages:

Find it:  >  **Messages** > **Message Inbox**

If a multimedia message contains media objects:

- Photos, graphics, and animations show as you read the message.
- An audio file plays when its slide shows. Use the volume keys to adjust the sound volume.
- Attached files are added to the end of the message. To open an attachment, scroll to the file indicator/file name and press **View** (images), **Play** (audio), or **Open** (contacts vCards, calendar vCalendar entries, or unknown file types).

memory card

You can use a removable memory card with your phone to store and retrieve multimedia objects (such as photos and audio).



Your phone supports optional microSD memory cards with up to 2 GB capacity (greater than 1 GB capacity is guaranteed only for SanDisk microSD cards).

Note: If you download a copyrighted file and store it on your memory card, you can use the file only while your memory card is inserted in your phone. You cannot send, copy, or change copyrighted files.

install or remove a memory card

1 Remove the battery door.

2 Press the memory card into its slot until it clicks into place.

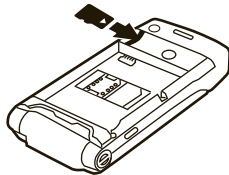

3 Set the battery door against the phone and then slide it into place.



To remove the memory card, slide it back out.

Do not remove your memory card while your phone is using it or writing files on it.

see and change memory card information

To **see the files** stored on your memory card and on your phone, open a file list, such as **Graphics** (see page 23). Icons can indicate if a file is stored in your phone memory () or on your memory card (). To **copy or move a file from your phone to your memory card**:



- 1 Select the file in the list and press **Options**.
- 2 Select **Manage**, then select **Copy** or **Move**.
- 3 Select **Memory Card**.

Note: You cannot copy or move some copyrighted files.

To **copy files** between your memory card and a computer, you can use a cable connection (see page 30) or a Bluetooth® connection (see page 16).

To see your **memory card name, available memory,** and other information about the card:

Find it:  >  **Settings** > **Phone Status** > **Storage Devices**

- 1 Press  to scroll to the memory card that is installed.
- 2 Press the *center key*  to see the memory card information. Your phone stores any content that you add, like ring tones or games, in *user memory*. Your service provider may store some

content in user memory before you receive the phone.

or

Press **Options** to see the **Storage Device** menu, which lets you **Format** or **Rename** the memory card.

cable connections

 Your phone has a mini-USB port so you can connect it to a computer to transfer data.

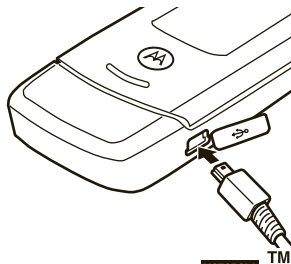

Note: Motorola Original USB data cables and supporting software are sold separately. Check your computer or hand-held device to



determine the type of cable you need. To **transfer data** between your phone and computer, you might need to install the software included with the Motorola Original data kit. See the data kit user's guide for more information. To make **data calls** through a connected computer, see page 71.

connect your memory card to a computer

You can use a cable connection to access your phone's memory card with a PC.

Note: When your phone is connected to a computer, you can only access the memory card through the computer.

On your phone:

Disconnect the cable from your phone, if it is connected, then:

Find it:  >  Settings > Connection > USB Settings
> Default Connection > Memory Card

This directs the USB connection to your memory card.

Connect the cable to your phone and to an available USB port on your computer. Then follow these steps:

On your computer:

- 1 Open your "My Computer" window, where your phone's memory card appears as a "Removable Disk" icon.
- 2 Click on the "Removable Disk" icon to access the files on your phone's memory card.
- 3 To store the desired files onto the memory card, drag and drop them as follows:
audio files: > mobile > audio
screen savers: > mobile > picture
wallpapers: > mobile > picture
video clips: > mobile > video
- 4 When you finish, disconnect your phone by selecting the "Safely Remove Hardware" icon in the system tray at the bottom of your computer

screen. Then disconnect the “USB Mass Storage Device.”

- 5 Disconnect the cable from your phone and computer.

On your phone:

To return to **Data** as your USB default connection:

Find it:  >  **Settings** > **Connection** > **USB Settings**
> **Default Connection** > **Data Connection**

phone updates

Sometimes we think of ways to make your phone’s software faster or more efficient after you’ve purchased your phone. You can find out if your phone can be updated at: <http://hellomoto.com/update>



Note: Software updates do not affect your contacts entries or other personal entries. If you receive a

software update but choose to install it later, see page 73.

basics

See page 1 for a basic phone diagram.

display

The *home screen* appears when you turn on the phone.

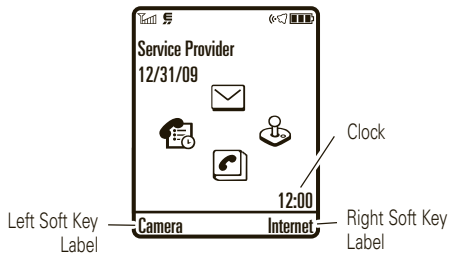

Note: Your home screen might look different from the one shown, depending on your service provider.



To dial a number from the home screen, press number keys and .

Press  up, down, left, or right in the home screen to open basic menu features.

Press the *center key*  to open the menu. *Soft key labels* show the current soft key functions. For soft key locations, see page 1.

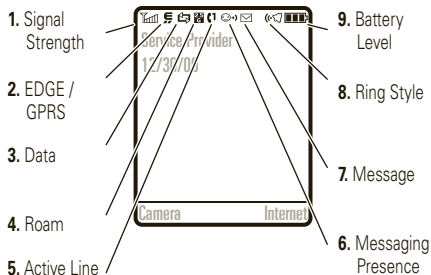
Status indicators can show at the top of the home screen:



- 1 Signal Strength Indicator** – Vertical bars show the strength of the network connection. You can't make or receive calls when  or  appears.
- 2 EDGE/GPRS Indicator** – Shows when your phone is using a high-speed  *Enhanced Data for GSM Evolution (EDGE)* or

General Packet Radio Service (GPRS) network connection. Indicators can include:

 GPRS available

 EDGE

 GPRS active

- 3 Data Indicator** – Shows connection status. 



secure / unsecure packet data transfer





secure/unsecure application connection





secure/unsecure *Circuit Switch Data (CSD)* call







Bluetooth® connection is active

- 4 Roam Indicator** – Shows  when your phone is seeking or using a network outside your home network. 

5 Active Line Indicator – Shows  to indicate an active phone call, or  to indicate when call forwarding is on. Indicators for dual-line-enabled SIM cards can include:



- | | |
|---|--|
|  line 1 active |  line 1 active, call forward on |
|  line 2 active |  line 2 active, call forward on |

6 Messaging Presence / Reminder Indicator – If you set a reminder for a calendar event,  can appear here.

When a Java™ application is active,  can show here.

7 Message Indicator – Shows when you receive a new message. Indicators can include:



- | | |
|--|---|
|  text message |  voice message |
|--|---|

 voice & text message

8 Ring Style Indicator – Shows the ring style setting.

- | | |
|---|---|
|  loud ring |  vibrate & ring |
|  soft ring |  vibrate then ring |
|  vibrate |  silent |

9 Battery Level Indicator – Vertical bars show the battery charge level. Recharge the battery when your display shows **Low Battery**.

text entry

Some features let you enter text.

For indicator descriptions see following section.

Flashing cursor indicates insertion point.

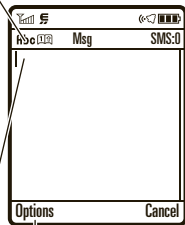

Press the **Options** key to open the submenu.







Press the **Cancel** key to exit without making changes.

Press **#** in a text entry view to select an entry mode:



entry modes	
1 or 1	Primary text entry mode can be set to any iTAP™ 1 or tap 1 mode.
2 or 2	Secondary text entry mode can be set to any iTAP 2 or tap 2 mode, or set to None if you don't want a secondary entry mode.
123	Numeric mode enters numbers only.
@%	Symbol mode enters symbols only.

To set primary and secondary text entry modes, press **Options** and select **Text Setup** in a text entry view, then select **Primary Text** or **Secondary Text**.

iTAP™ and tap mode tips

- Press  in a text entry view to change text case to all capital letters (**ABC**), no capitals (**abc**), or next letter capital (**Abc**).
- To enter numbers quickly, press and hold a number key to temporarily switch to numeric mode. Press the number keys to enter the numbers you want. Enter a space to change back to iTAP or Tap mode.
- Press  to enter punctuation or other characters.
- Press  to move the flashing cursor to enter or edit message text.
- Press  to delete the character to the left of the cursor. Hold  to delete the word.
- To cancel your message, press .

iTAP™ mode

Press  in a text entry view to switch to iTAP mode. If you don't see  or , press **Options** and select **Text Setup** to set iTAP mode as your primary or secondary text entry mode.

iTAP mode lets you enter words using one keypress per letter. The iTAP software combines your keypresses into common words and predicts each word as you enter it.

For example, if you press **7 7 6 4**, your display shows:

Hold **⊙** up or down to see a list of word options.

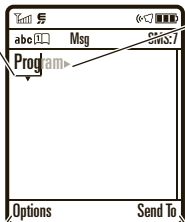

Press **⊙** right to accept **Program**.

To enter a space, press **⊞**.

Press the **Options** key to open message options.

To delete, press **⊞**.

Press the **Send To** key when the message is complete.

If you want a different word (such as **Progress**), continue pressing keypad keys to enter the remaining letters.

Tip: Don't worry if you forget how iTAP works. In a text entry display, you can press **Options** and select **Text Setup**, then **Text Tutorial**, to see an explanation.

tap and tap extended modes

Press **#** in a text entry view to switch to tap mode. If you don't see **Abc1** or **Abc2**, press **Options** and select **Text Setup** to set tap mode as your primary or secondary text entry mode.

To enter text in **Tap** mode, press a keypad key repeatedly to cycle through the letters and number on the key. Repeat this step to enter each letter. The **Tap Extended** mode works the same way, but includes more special characters and symbols.

For example, if you press **7** one time, your display shows:

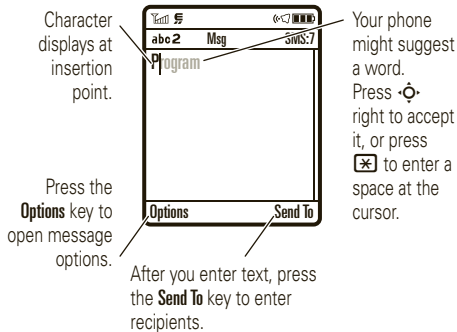

The first character of every sentence is capitalized. If necessary, press **↵** down to change the character to lowercase before the cursor moves to the next position.

numeric mode

Press **#** in a text entry view until you see **123**. Press the number keys to enter the numbers you want.

Shortcut: You can press and hold a number key to temporarily switch to numeric mode from iTAP™ or Tap modes. Press the number keys to enter the numbers you want. Enter a space to change back to iTAP mode.

symbol mode

Press **#** in a text entry view until your display shows a list of symbols. Scroll to the symbol you want, then press the *center key* **⬇**.

volume

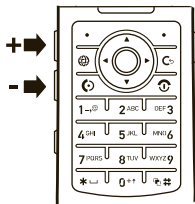

Press the volume keys to:

- turn off an incoming call alert
- change the earpiece volume during calls
- change the ringer volume from the home screen



Tip: Sometimes silence really is golden. That's why you can quickly set your ringer to **Vibrate** or **Silent** by holding the down volume key while you are in the home screen. You can also switch to **Silent** or back by holding **#** in the home screen.

navigation key

Press the *navigation key*  up, down, left, or right to scroll to items in the display. When you scroll to an item, press the *center key*  to select it.

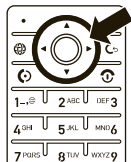

voice commands

You can use voice commands to tell your phone what to do.

- 1 Press and release the **voice key** on the left side of your phone.

Your phone prompts you to say a command.

- 2 Say a voice command from the list (replace 555-1212 with a phone number, and replace *John Smith* with a contacts entry name):

voice commands
"Call 555-1212"
"Call John Smith"
"Send Email John Smith"
"Send Voice Note 555-1212"
"Send Voice Note John Smith"
"Send Message 555-1212"
"Send Message John Smith"
"Lookup John Smith"
"Go to Voicemail"
"Go to Camera"
"Go to Redial"

voice commands
"Go to Received Calls"
"Check Status"
Your phone tells you its battery strength, network signal strength, and whether its coverage is normal or roaming.
"Check Battery"
"Check Signal"
"Check Network"
"Check My Phone Number"
"Turn Prompts Off"
Your phone turns off the sound on your voice command prompts (such as "Say a command."). To turn prompts on again, say " Turn Prompts On. " Your phone confirms by saying "Voice prompts on."

Tip:

- You can say a contact entry's name and number type together. For example, say "Call John Smith Mobile" to call the Mobile number stored for John Smith.
- Speak numbers at a normal speed and volume, pronouncing each digit distinctly. Don't pause between digits.
- For voice command help, press the **voice key**, then press **Help**.

voice command setup

You can change voice command settings.

- 1 Press and release the **voice key** on the left side of the phone.
- 2 Press **Settings**.

- 3 Choose one of the settings below:

voice command settings	
Choice Lists	Turn choice lists on or off. Your phone uses choice lists to confirm voice commands by asking "Did you say..." followed by a choice list item.
Sensitivity	Make your phone more or less likely to reject a voice command.
Digit Dialing	Train your phone to recognize how you say digits.
Audio	Adjust the audio settings for your voice commands.
About	See voice command software information.

external display

When your phone is closed, the external display shows the time, date, status indicators, and notifications for incoming calls and other events. For a list of phone status indicators, see page 33.

handsfree speaker

You can use your phone's handsfree speaker to make calls without holding the phone to your ear.

To turn the handsfree speaker on during a call, press **Speaker** (if available), or press **Options** and select **Spkrphone On**. Your display shows **Spkrphone On** until you turn it off or end the call.

Note: The handsfree speaker won't work when your phone is connected to a handsfree car kit or headset.

codes & passwords

Your phone's four-digit **unlock code** is originally set to **1234**. The six-digit **security code** is originally set to **000000**. If your service provider didn't change these codes, you should change them:

Find it:  >  **Settings** > **Security** > **New Passwords**

You can also change your **SIM PIN** password.



If you forget your unlock code: At the **Enter Unlock Code** prompt, try entering 1234 or the last four digits of your phone number. If that doesn't work, press  and enter your six-digit security code instead.

If you forget other codes: If you forget your security code, SIM PIN code, PIN2 code, or call barring password, contact your service provider.

lock & unlock phone

You can lock your phone to keep others from using it. To lock or unlock your phone, you need the four-digit unlock code.

To **manually lock** your phone:

Find it:  >  Settings > Security > Phone Lock > Lock Now

To **automatically lock** your phone whenever you turn it off:

Find it:  >  Settings > Security > Phone Lock > Automatic Lock > On

Note: You can make emergency calls on a locked phone (see page 53). A locked phone still rings or vibrates for incoming calls or messages, **but you need to unlock it to answer.**

lock & unlock external keys

When your phone is closed, your external keys (such as the smart key and volume keys) lock to prevent accidental key presses.

Note: Your phone will not lock external keys if an action is in process. For instance, if you close your phone and press a volume key right away, your phone shows your ring style profile. Your external keys remain unlocked until you close the ring style profile.

To change how long your phone waits before it automatically locks your external keys:

Find it:  >  Settings > Security > External Key Lock > Timer > *a time interval* or Off

Note: If you choose **Off**, you can still manually lock your external keys by holding the smart key.

customize

talking phone

When you receive calls, your phone can “speak” the caller’s number or name rather than ringing. Also, your phone can read names to you when you scroll through your contacts, and can speak digits to you as you enter them to make a call. To turn these features on or off:

Find it:  >  Settings > Personalize > Sound Settings
> Talking Phone

Your phone speaks the name for any caller stored in your contacts, or speaks the digits for numbers not stored in your contacts.

Note: If you turn on **Talking Phone**, your phone **does not use** your **Ring Style** for incoming calls.

ring style

Each ring style profile uses a different set of sounds or vibrations for incoming calls and other events. Here are the profiles you can choose:



The ring style profile’s indicator appears at the top of your home screen. To choose your profile:

Find it:  >  Settings > Ring Styles > Style: *style name*

Shortcut: To change your ring style profile from the home screen, just press the volume keys up or down.

change alerts in a ring style

You can change the alerts for incoming calls and other events. Your changes are saved in the current ring style profile.

Find it:  >  Settings > Ring Styles > style Detail

Note: *Style* represents the current ring style. You can't set an alert for the **Silent** ring style setting.

- 1 Scroll to **Calls** (or **Line 1** or **Line 2** for dual-line phones), then press **Change** to change it.
- 2 Scroll to the alert you want, then press the *center key* .
- 3 Press **Back** to save the alert setting.

time & date

Your phone can automatically update your time zone, time, and date. It uses the time and date for the calendar.

To **synchronize** the time zone, time, and date with the network:





Find it:  >  Settings > Initial Setup > Time and Date > Autoupdate > Time & Time Zone

If you don't want your phone to automatically update your time zone and date, choose **Time Only** instead.

To **manually** set the time zone, time, and date, turn off **Autoupdate**, then:

Find it:  >  Settings > Initial Setup > Time and Date > Time Zone, *time* or *date*

To jump to a city in the time zone list, enter the first letter of its name by pressing keypad keys.

Tip: To choose three time zones for easier access, press  >  Tools > World Clock. When you open **World Clock**, you can press **Options** to see the **Map View** of time zones.

To choose an **analog or digital** clock for your home screen:

Find it:  >  Settings > Personalize > Home Screen > Clock

wallpaper

Set a photo, graphic, or animation as a wallpaper (background) image in your home screen.

Find it:  >  Settings > Personalize > Wallpaper

options	
Graphic	Press  up or down to select a graphic, or select None for no wallpaper.
Layout	Select Center to center the image in the display, Tile to repeat the image across the display, or Fit-to-screen to stretch the image across the display.

screen saver

Set a photo, graphic, or animation as a screen saver. The screen saver appears when the flip is open and no activity is detected for a specified time.

Tip: To extend battery life, turn off the screen saver.

Find it:  >  Settings > Personalize > Screen Saver

options	
Graphic	Press  up or down to select a graphic or animation, or select None for no screen saver.
Delay	Select the length of inactivity before the screen saver appears.

themes

A *phone theme* is a group of image and audio files that you can apply to your phone. Most



themes include a wallpaper image, screen saver image, and ring tone. Your phone may come with some themes, and you can download more.

To **apply** a theme:

Find it:  >  Multimedia/Sounds > Themes > *theme*

To **download** a theme, see page 79.

To **delete themes you downloaded:**

Find it:  >  Multimedia/Sounds > Themes

Scroll to the theme and press **Options**, then select **Delete** or **Delete All**

display appearance

To choose a phone **skin** that sets the look and feel of your phone's display:

Find it:  >  Settings > Personalize > Skin

To set display **brightness:**

Find it:  >  Settings > Initial Setup > Brightness

To save battery life, your keypad **backlight** turns off when you're not using your phone. The backlight turns on when you open the flip or press any key. To set how long your phone waits before the backlight turns off:

Find it:  >  Settings > Initial Setup > Backlight

To save battery life, the **display** can turn off when you're not using your phone. The display turns back on when you open the flip or press any key. To set how long your phone waits before the display turns off:

Find it:  >  Settings > Initial Setup > Display Timeout

shortcuts and main menu

home screen shortcuts

In the home screen, you can press the navigation key or soft keys as **shortcuts** to your favorite features. You can change the features that these keys open. For key locations, see page 1.



Find it:  >  Settings > Personalize > Home Screen > Home Keys

options	
Icons	Show or hide your navigation key shortcut icons in the home screen.

options	
Up, Down, Left, Right	Choose the features that open when you press the navigation key up, down, left, or right in the home screen.
Left Soft Key	Choose the feature that opens when you press the <i>left soft key</i> in the home screen.
Right Soft Key	Choose the feature that opens when you press the <i>right soft key</i> in the home screen.

main menu appearance

To make your **main menu appearance** either graphic icons or a text-based list:

Find it:  >  Settings > Personalize > Main Menu > View > Icons or List

To change your **main menu order**:

Find it:  >  Settings > Personalize > Main Menu > Reorder

answer options

You can use different ways to answer an incoming call.

To turn on or turn off an answer option:

Find it:  >  Settings > In-Call Setup > Answer Options

options	
Multi-Key	Answer by pressing any key.
Open to Answer	Answer by opening the flip.
Delayed Answer	Set up your delayed answering option (see page 50).

calls

To make and answer calls, see page 13.

turn off a call alert

You can press the volume keys to turn off a call alert before answering the call.

delay answering

If you want to answer a call, but need to step outside first, you can delay answering the call.

When your phone rings, press **Delay** or your voice key. Your phone stops ringing and plays a brief message for the caller, such as “Please hold, your call will be answered in a moment.” The call remains on hold until you press **Talk**.

To turn **Delayed Answer** on, or record your **Delayed Answer** message (up to 10 seconds):

Find it:  >  **Settings** > **In-Call Setup** > **Answer Options** > **Delayed Answer**



Note: When **Delayed Answer** is on, the **Open to Answer** feature is disabled.

call history



Your phone keeps lists of incoming and outgoing calls, even for calls that didn't connect. The most recent calls are listed first. The oldest calls are deleted as new calls are added.

Shortcut: Press  from the home screen to see a list of dialed calls.

Find it: > Call History





Press  or  to switch to **Dialed Calls**, **Received Calls**, or **Missed Calls**.

Scroll to a call. A  next to a call means the call connected.



- To call the number, press .
- To see call details (like time and date), press the *center key* .
- To see the **Last Calls Menu**, press **Options**. This menu can include:



options	
Store	Create a contacts entry with the number in the No. field. Store does not appear if the number is already stored.
Delete	Delete the entry.

options	
Delete All	Delete all entries in the list.
Show ID	Show your caller ID for the next call.
Hide ID	Hide your caller ID for the next call.
Send Message	Open a new text message with the number in the To field.
Send Voice Message	Record and send a voice message to the number.
Add Digits	Add digits after the number.
Attach Number	Attach a number from the contacts or call history lists.
Send Tones	Send the number to the network as DTMF tones. Note: This option appears only during a call .

options	
Talk then Fax	Talk and then send a fax in the same call (see page 71). 
Filter by	Select all, dialed, received, or missed calls.
Notepad	Open the number in a text editor.
Call Times	Open your call time information. 
Call Cost	Open your call cost information. 
Data Times	See how much time you have spent on data transfers. 
Data Volumes	See how much data you have transferred. 

redial

- 1 Press  from the home screen to see a list of recent calls.
- 2 Scroll to the entry you want to call, then press .

If you hear a **busy signal**, and you see **Call Failed**, you can press  or **Retry** to redial the number. 

When the call goes through, your phone rings or vibrates one time, shows **Redial Successful**, and connects the call.

return a call

Your phone keeps a record of your unanswered calls, and shows **X Missed Calls**, where **X** is the number of missed calls.

- 1 Press **View** to see the received calls list.

- 2 Scroll to the call you want to return, then press .

caller ID

Calling line identification (caller ID) shows the phone number for an incoming call in your external and internal displays.



Your phone shows the caller's name and graphic when they're stored in your contacts, or **Incoming Call** when caller ID information isn't available.

You can set your phone to play a different ringer ID for an entry stored in your contacts (see page 61).

To show or hide **your phone number** from the next person you call, enter the phone number and press **Options**, then select **Hide ID/Show ID**.

emergency calls

Your service provider programs one or more emergency phone numbers, such as 911 or 112, that you can call under any circumstances, even when your phone is locked or the SIM card is not inserted.

Note: Emergency numbers vary by country. Your phone's preprogrammed emergency number(s) may not work in all locations, and sometimes an emergency call cannot be placed due to network, environmental, or interference issues.

- 1 Press the keypad keys to dial the emergency number.
- 2 Press  to call the emergency number.

voicemail

Your network stores the voicemail messages you receive. To listen to your messages, call your voicemail number.



Note: Your service provider may include additional information about using this feature.

When you **receive** a voicemail message, your phone shows the voicemail message indicator  and **New Voicemail**. Press **Call** to listen to the message.

To **check** voicemail messages:

Find it:  >  **Messages** > **Voicemail**

Your phone may prompt you to store your voicemail phone number. If you don't know your voicemail number, contact your service provider.

Note: You can't store a **p** (pause), **w** (wait), or **n** (number) character in this number. If you want to store a voicemail number with these characters, create a

contacts entry for it. Then you can use the entry to call your voicemail.

To **change** your voicemail number or turn off voicemail notification:

Find it:  >  **Messages**

Press **Options** and select **Setup**, then select **Voicemail Setup**



Tip: To open a list of your **Missed Calls**, see page 50.

other features

advanced calling

To use voice commands for calling, see page 39.

features	
attach a phone number	
Dial an area code or prefix for a contact entry's number, then press Options and select Attach Number .	

features
notepad
 >  Call History
Press Options , then select Notepad .
<ul style="list-style-type: none">• To call the number, press .• To create a contacts entry with the number in the No. field, press Store.• To open the Dialing Menu to attach a number or insert a special character, press Options.

features

international calls



If your phone service includes international dialing, press and hold **0** to insert your local international access code (indicated by +). Then, press the keypad keys to dial the country code and phone number.

hold a call

Press **Options** and select **Hold** to put all active calls on hold.

mute a call

Press **Mute** (if available), or press **Options** and select **Mute**, to put all active calls on mute.

features

call waiting









When you're on a call, you'll hear an alert if you receive a second call.







Press **☎** to answer the new call.

- To switch between calls, press **Switch**.
- To connect the two calls, press **Options** and select **Link**.
- To end the call on hold, press **Options** and select **End Call On Hold**.

To turn the call waiting feature on or off:

 >  **Settings** > **In-Call Setup** > **Call Waiting** > **On** or **Off**

features	
<p>conference call</p> <p>During a call:</p> <p>Dial the next number, press , then press Options and select Link.</p>	
<p>transfer a call</p> <p>During a call, press Options, select Transfer, dial the transfer number, and press </p>	
<p>call forwarding</p> <p>Set up or cancel call forwarding:</p> <p> >  Settings > Call Forward</p>	

features	
<p>restrict calls</p> <p>Restrict outgoing or incoming calls:</p> <p> >  Settings > Security > Restrict Calls</p> <p>Tell your phone to allow All, None, or only the calls from your contacts.</p>	
<p>call barring</p> <p>Restrict outgoing or incoming calls:</p> <p> >  Settings > Security > Call Barring</p>	

features

TTY calls



Set up your phone for use with an optional TTY device:

 >  **Settings** > **Initial Setup** > **TTY Setup**

Note: A teletypewriter (TTY) is a communication device used by people who are hard of hearing or have a speech impairment. TTY does not work from mobile phone to mobile phone.

change phone line



If you have a dual-line-enabled SIM card, you can change your line to make and receive calls from your other phone number.

 >  **Settings** > **Phone Status** > **Active Line**

features

fixed dial



When you turn on fixed dialing, you can call only numbers stored in the fixed dial list.

Turn fixed dialing on or off:

 >  **Settings** > **Security** > **Fixed Dial**

Use the fixed dial list:

 >  **Tools** > **Dialing Services** > **Fixed Dial**

service dial



Your service provider might give you phone numbers for taxi companies or other services. These phone numbers are stored on your SIM card. To see them:

 >  **Tools** > **Dialing Services** > **Service Dial**

features

quick dial



Dial preprogrammed phone numbers:

> Tools > Dialing Services > Quick Dial

DTMF tones

Activate DTMF tones:

> Settings > Initial Setup > DTMF

When you dial a number, your phone sends it to your network as *Dual Tone Multi Frequency* (DTMF) tones.

To send DTMF tones during a call, just press number keys or scroll to a number in the contacts or call history lists and press **Options** and select **Send Tones**.

contacts

To store and call contacts entries, see page 13.

Note: You can show contacts stored in your phone's memory or on your SIM card. To choose which entries you see, press > **Contacts**, then press **Options** and select **View**. You can select **Phone & SIM Card**, **SIM Card**, or **Phone Contacts**.

features

assign a speed dial key to a contacts entry

You can assign the keys **1** through **9** to contacts entries. Then, when you press and hold a key, your phone calls the entry.

Note: Your service provider might assign some keys, such as **1** for your voicemail number.

> **Contacts**

Scroll to the contacts entry, press **Options** and select **Add to Speed Dial**, then select a speed dial key.

features

use the speed dial key for a contacts entry

To **use a speed dial key** that you assigned to a contacts entry, just press and hold the key while in your home screen.

edit your speed dial keys

 >  **Contacts**

Press **Options** and select **Manage Contacts**, then select **Speed Dial**.

choose a speed dial key list

You can set speed dial to call contacts stored in phone memory or numbers on your Fixed Dial list:



 >  **Settings** > **Initial Setup** > **Speed Dial**
> **Phone Memory** or **Fixed Dial**.



features

edit or delete a contacts entry

Edit a number stored in your contacts:

 >  **Contacts**

Scroll to the contacts entry and press **Options**. You can select **Edit Contact**, **Delete Contact**, or other options

Shortcut: In the contacts list, enter the first letters of an entry you want to jump to entries that match those letters. You can also press  and  to see the entries in your categories or entries you used recently.

features

set ringer ID for a contacts entry

Assign a ring alert (ringer ID) to an entry:

 >  **Contacts**

Scroll to the entry and press **Options**, then select **Edit Contact**. Select **Ringer ID**, then scroll to and select a ringer.

Note: The **Ringer ID** option isn't available for entries stored on the SIM card. To copy an entry from SIM to phone memory, see page 64.

To activate ringer IDs:

 >  **Settings** > **Ring Styles** > *style* **Detail** > **Ringer IDs**
> **On**

features

set picture ID for a contacts entry

Assign a photo or graphic to show when you receive a call from an entry:

 >  **Contacts**

Scroll to the entry and press **Options**, then select **Edit Contact**. Select **Graphic**, then scroll to and select a graphic.

Note: The **Graphic** option isn't available for entries stored on the SIM card. To copy an entry from SIM to phone memory, see page 64.



features

set category for a contacts entry



Scroll to the entry and press **Options**, then select **Edit Contact**. Select **Category**, then scroll to and select a category.

Note: The **Category** option isn't available for entries stored on the SIM card. To copy an entry from SIM to phone memory, see page 64.

When you open your contacts, press  or  to see your categories.



features

set category view for contacts



Scroll to the entry and press **Options**, then select **Filter by**. Select **Category**, then scroll to and select a category.

You can show **All** entries, entries in a predefined category (**Business**, **Personal**, **General**, **VIPs**), or entries in a category you create.

Shortcut: When you open your contacts, press  or  to see your categories.

features

create a new category

 >  Contacts

Scroll to the entry and press **Options**, then select **Manage Contacts**. Select **Edit Phone Categories**, then select **[New Category]**.

Enter the category name, and select its members from your contacts entries.

edit a category

 >  Contacts

Press **Options** and select **Manage Contacts**, then select **Edit Phone Categories**. Scroll to the category name and press **Options**, then select **Edit Category**.

You can edit the category name, members, ringer ID, or graphic. Your phone uses the ringer ID and graphic whenever you receive calls from numbers in the category.

features

create group mailing list

You can put several contacts entries in a group mailing list, then send a message to the list. To create a list:

 >  Contacts

Press **Options** and select **Create New**, then select **Message List**.

Note: A **Message List** cannot include entries stored on the SIM card. To copy an entry from SIM to phone memory, see page 64.

sort contacts list

Set the order in which entries are listed:

 >  Contacts

Press **Options** and select **Setup**. Select **Sort by**, then select **First Name** or **Last Name**.

features

copy one contacts entry

Copy an entry from the phone to the SIM card, or from the SIM card to the phone:



Scroll to the entry and press **Options**, then select **Copy to SIM Card** or **Copy to Phone**.

copy multiple contacts entries

Copy multiple contacts entries between the phone and SIM card:



Press **Options** and select **Select Multiple to**, then select **Copy Phone to SIM** or **Copy SIM to Phone**.

features

send contacts entry to another device

Send a contacts entry to another phone, computer, or device:



Scroll to the entry and press **Options**, then select **Send Contact**.

print contacts entry over Bluetooth® connection



You can use a Bluetooth wireless connection to send a contacts entry from your phone to a printer.









Scroll to the entry you want to print, press **Options**, then select **Print**.

You cannot print a **Mailing List**. For more about Bluetooth connections, see page 15.

messages

For basic text message features, see page 26.

features	
send email	
◀  >  Messages > Create Message > New Email	
send voice message	
◀  >  Messages > Create Message > New Voice Msg	
<p>Your phone starts recording the voice message. To stop recording, press Stop. Your phone inserts the voice recording into a message and lets you enter email addresses or phone numbers of the recipients.</p>	

features

use a message template

◀  >  Messages > Templates > Text Templates or
Multimedia Templates







Select a template to create a new message based on the template.

features

read and manage messages



 >  Messages > Message Inbox

Icons next to each message indicate if it is read  or unread . Icons can also indicate if the message has an attachment , might be SPAM , or is locked , urgent , or low priority .

To **Reply**, **Forward**, **Lock**, or **Delete** a message, scroll to it and press **Options**.

To open a message, press . Then, you can press **Options** to use or store any phone numbers, email addresses, Web sites, or files in the message.

features

read and manage email



 >  Messages > Email Msgs

To **Reply**, **Forward**, **Lock**, or **Delete** a message, scroll to it and press **Options**.

To open a message, press . Then, you can press **Options** to use or store any phone numbers, email addresses, Web sites, or files in the message.

store message objects



Go to a multimedia message page, or scroll to an object in a message, then press **Options** and select **Store**.

features

print message over Bluetooth® connection



You can use a Bluetooth wireless connection to send a message from your phone to a printer.

 >  Messages > Message Inbox, Email Msgs, Outbox, or Drafts

Scroll to the message you want to print and press **Options**, then select **Print**.

You cannot print message **Templates**. For more about Bluetooth connections, see page 15.

features

store text messages on your SIM card



To store incoming text messages on your SIM card, press:

 >  Messages

Press **Options** and select **Setup**. Select **Message Setup**, then **Text Msg Setup**, then **Default Storage**, and, finally, **SIM Card**.

features

edit email settings





You can edit the settings for your Email connections. To use email, you need to store your email **User ID** and **Password**.

 >  Messages

Press **Options** and select **Setup**, then select **Email Msg Setup**, and then **Account Settings**.

If you have more than one email account, select an account to edit.

Your phone shows a list of email settings. Here is where you store your email **User ID** and **Password**.

Note: To create a new account, select **[New Entry]** in the **Account Settings** list. Your display shows a folder for each email account under  >  Messages > **Email Msgs**.

features

browser messages



Read messages received by your micro-browser:

 >  Messages > **Browser Msgs**

info services



Read subscription-based information services messages:

 >  Messages > **Info Services**

personalizing

features

language

Set menu language:

 >  Settings > **Initial Setup** > **Language**

features
<p>scroll</p> <p>Set the scroll bar to Up/Down or Wrap Around in menu lists:</p> <p>◀ ● ▶ > ⚙ Settings > Initial Setup > Scroll</p>
<p>text marquee</p> <p>Set the speed for scrolling text in your display:</p> <p>◀ ● ▶ > ⚙ Settings > Initial Setup > Text Marquee</p>
<p>activate ringer IDs</p> <p>Activate ringer IDs assigned to contacts entries and categories:</p> <p>◀ ● ▶ > ⚙ Settings > Ring Styles > <i>style</i> Detail > Ringer IDs</p>
<p>ring volume</p> <p>◀ ● ▶ > ⚙ Settings > Ring Styles > <i>style</i> Detail > Ring Volume</p>

features
<p>keypad volume</p> <p>◀ ● ▶ > ⚙ Settings > Ring Styles > <i>style</i> Detail > Key Volume</p>
<p>reminders</p> <p>Set a reminder for when you have not responded to an incoming call, message, or other event:</p> <p>◀ ● ▶ > ⚙ Settings > Ring Styles > <i>style</i> Detail > Reminders</p>
<p>master reset</p> <p>Reset all options except unlock code, security code, and lifetime timer:</p> <p>◀ ● ▶ > ⚙ Settings > Initial Setup > Master Reset</p>

features

master clear

Caution: Master clear **erases all information you have entered** (including contacts and calendar entries) **and content you have downloaded** (including photos and sounds) stored in your phone's memory. After you erase the information, you can't recover it.

 >  Settings > Initial Setup > Master Clear

call times & costs

Network connection time is the elapsed time from the moment you connect to your service provider's network to the moment you end the call by pressing . This time includes busy signals and ringing.

The amount of network connection time you track on your resettable timer may not equal the

70 other features—call times & costs

amount of time for which you are billed by your service provider. For billing information, contact your service provider.

features

call times

Show call timers:

 >  Call History

Press **Options**, then select **Call Times**.

in-call timer

Show time or cost information during a call:

 >  Settings > In-Call Setup > In-Call Timer

call cost





Show call cost trackers:







 >  Call History

Press **Options**, then select **Call Cost**.

handsfree

Note: The use of wireless phones while driving may cause distraction. Discontinue a call if you can't concentrate on driving. Additionally, the use of wireless devices and their accessories may be prohibited or restricted in certain areas. Always obey the laws and regulations on the use of these products.

features	
speakerphone	
Activate the speakerphone during a call: Press Speaker (if available), or press Options and select Spkrphone On .	
auto answer (car kit or headset)	
Automatically answer calls when connected to a car kit or headset:  >  Settings > Car Settings or Headset > Auto Answer	

features	
voice dial (headset)	
Enable voice dial with headset send/end key:  >  Settings > Headset > Voice Dial	
auto handsfree (car kit)	
Automatically route calls to a car kit when connected:  >  Settings > Car Settings > Auto Handsfree	

data calls

To connect your phone with a USB cable, see page 29.

features	
send data	
Connect your phone to the device, then place the call through the device application.	

features

receive data or fax



Connect your phone to the device, then answer the call through the device application.

talk then fax



Connect your phone to the device, enter fax number, press **Options** and select **Talk then Fax**, then press  to make the call.

features

set up Exchange ActiveSync



You can use the Internet to synchronize your phone's contacts and calendar entries with an email account on a Microsoft® Exchange 2003 Server.



You need to know the email account's **user name** and **password**, the Microsoft® Exchange **server name**, and the **user domain name**. Confirm that the **Mobility** option is enabled on the email account, and that **data service** is activated with your phone service provider.

To **set up** an ActiveSync partner:

 >  **Settings** > **Connection** > **MOTOSYNC** > **Exchange**

Press **Options**, then select **Setup**. Enter the server details, including **Server Name**, **Domain**, and the **Web Session** to use. To set up a **Web Session**, see page 80.

features

use Exchange ActiveSync

Once you set up an Exchange ActiveSync partner, you can schedule your phone to synchronize with the account automatically.

To **schedule** synchronization:

 >  **Settings** > **Connection** > **MOTOSYNC** > **Exchange**

Press **Options**, then select **Auto Sync Setup**. Enter the time and days you want your phone to synchronize.



network

features

network settings

See network information and adjust network settings:

 >  **Settings** > **Network**

software update

Your service provider can send updated phone software over the air to your phone. When your phone receives a software update, you can choose to download it and install it later. To install a software update you downloaded:

 >  **Settings** > **Phone Status** > **Software Update**
> **Install Now**



personal organizer

features

set alarm

 >  Tools > Alarm Clock

turn off alarm



When an alarm happens: To turn off the alarm, press **Disable** or . To set an eight-minute delay, press **Snooze**.

Note: **Snooze** is available only if the phone is already powered on when the alarm sounds.

features

add new calendar event

 >  Tools > Calendar

Scroll to the day and press , then scroll to **Create New Event**, and press .



If you set a reminder for a calendar event,  can appear at the top of your screen.

features

see calendar event

See or edit event details:

 >  Tools > Calendar

Scroll to the day and press . Scroll to the event and press . To edit the details, press **Options** and select **Edit**.

Tip: Keeping up with life can be tough work. To see a list of your upcoming events, open the calendar and press **Options** and select **View**, then select **Organized Events**.

event reminder

When an event reminder happens: To see reminder details, press **View**. To close the reminder, press **Exit**.

features

send calendar event to another device

Send a calendar event to another phone, computer, or device:

 >  Tools > Calendar

Scroll to the day and press . Scroll to the event and press **Options**, then select **Send**, then **with Bluetooth**.

features

print calendar month, week, or day over Bluetooth® connection



You can use a Bluetooth wireless connection to send a calendar month, week, or day from your phone to a printer.

 >  Tools > Calendar

Go to the month, week, or day view and press **Options**, then select **Print**.

For more about Bluetooth connections, see page 15.

features

create voice record

Press and hold the voice key, speak into the phone, release the voice key.

Note: Recording phone calls is subject to varying state and federal laws regarding privacy and recording of conversations. Always obey the laws and regulations on the use of this feature.

play voice record

Play back a voice record:

 >  Multimedia/Sounds > Audio

Scroll to the voice record and press the *center key* .

calculator

 >  Tools > Calculator

features

currency converter

 >  Tools > Calculator

Press **Options** and select **Exchange Rate**. Enter the exchange rate and press **OK**. Enter the amount and press **Options**, then select **Convert Currency**.

security

features

SIM PIN

Caution: If you enter an incorrect PIN code three times before the correct code, your SIM card is disabled and your display shows **SIM Blocked**.

Lock or unlock the SIM card:

 >  Settings > Security > SIM PIN

features

lock feature

 >  Settings > Security > Lock Application

manage certificates



Enable or disable Internet access certificates stored on your phone:

 >  Settings > Security > Certificate Mgmt

Certificates are used to verify the identity and security of Web sites when you download files or share information.

fun & games

For basic information on the camera, see page 20.

features

listen to audio files

 >  Multimedia/Sounds > Audio



Scroll to a file and select it to listen.

features

delete or manage audio files

 >  Multimedia/Sounds > Audio

To **delete** a file, scroll to it in the list and press **Options**, select **Manage**, then select **Delete**.

To **copy or move** a file from your memory card () to your phone memory () scroll to it and press **Options**, select **Manage**, then select **Copy** or **Move**, then select **Memory Card**. You cannot copy or move some copyrighted files. 

To **categorize** audio files, press **Options** and select **Categories**. You can create categories, assign files, and choose which category shows in your **Audio** list.

start micro-browser

Just press . 

features

download objects from Web page



Download a graphic, audio file, or other object from a Web page:

Press , go to the page that links to the file, scroll to the link, and select it.

To activate downloaded copyrighted files:

 >  Tools > Activation List

Select a file type, then select a file. You can see the file's **Status**, **Type**, **Activation**, and **Counts Remaining**.

features

store downloaded files in your phone or memory card

You can choose to store your downloaded files on your phone or your memory card:

 >  Settings > Phone Status > Download Location > Memory Card or Phone

To see how much memory is available on your phone or memory card, see page 28.

video streaming online

If you go to a Web site with videos, your phone can play the videos in your browser without downloading them onto your phone. This is called *video streaming*.

To try video streaming, just start your micro-browser and go to a page that provides videos for streaming.

features

Web sessions



A *Web Session* stores settings that your phone uses to access the Internet. To select or create a Web session:

 >  Internet > Web Sessions

clear micro-browser history



Clear the micro-browser's history, cache, or cookies:

 >  Internet > Browser Setup > Clear History, Reset Cache, or Clear Cookies

features

download game or application



You can download a Java™ game or application the same way you download graphics or other objects:

Press , go to the page that links to the file, scroll to the link, and select it.

features

start game or application



Start a Java™ game or application:

 >  Games & Apps

Scroll to the game or application and press the *center key* .

To **pause** a Java app, press  or close the flip. When you start the Java app again, it will resume where you left off.

Note: Java apps will close and end if you open the camera.

To **install** and run games stored on your memory card:

 >  Games & Apps > [Install New]

features

airplane mode

You can switch your phone to airplane mode to prevent it from communicating with the network. This lets you use games or other applications while you are on an airplane, without interfering with airplane communications.

Note: Your phone cannot make Bluetooth® connections when **Airplane Mode** is on.

 >  Settings > Airplane Mode > Airplane Mode > On

You can make the airplane mode option appear whenever you turn on your phone:

 >  Settings > Airplane Mode > Prompt At Power Up > On

service & repairs

If you have questions or need assistance, we're here to help.

Go to www.motorola.com/consumer/support, where you can select from a number of customer care options. You can also contact the Motorola Customer Support Center at 1-800-331-6456 (United States), 1-888-390-6456 (TTY/TDD United States for hearing impaired), or 1-800-461-4575 (Canada).

Specific Absorption Rate Data

This model wireless phone meets the government's requirements for exposure to radio waves.

Your wireless phone is a radio transmitter and receiver. It is designed and manufactured not to exceed limits for exposure to radio frequency (RF) energy set by the Federal Communications Commission (FCC) of the U.S. Government and by the Canadian regulatory authorities. These limits are part of comprehensive guidelines and establish permitted levels of RF energy for the general population. The guidelines are based on standards that were developed by independent scientific organizations through periodic and thorough evaluation of scientific studies. The standards include a substantial safety margin designed to assure the safety of all persons, regardless of age or health.

The exposure standard for wireless mobile phones employs a unit of measurement known as the Specific Absorption Rate, or SAR. The SAR limit set by the FCC and by the Canadian regulatory authorities is 1.6 W/kg.¹ Tests for SAR are conducted using standard operating positions accepted by the FCC and by Industry Canada with the phone transmitting at its highest certified power level in all tested frequency bands. Although the SAR is determined at the highest certified power level, the actual SAR

level of the phone while operating can be well below the maximum value. This is because the phone is designed to operate at multiple power levels so as to use only the power required to reach the network. In general, the closer you are to a wireless base station, the lower the power output.

Before a phone model is available for sale to the public in the U.S. and Canada, it must be tested and certified to the FCC and Industry Canada that it does not exceed the limit established by each government for safe exposure. The tests are performed in positions and locations (e.g., at the ear and worn on the body) reported to the FCC and available for review by Industry Canada. The highest SAR value for this model phone when tested for use at the ear is 1.08 W/kg, and when worn on the body, as described in this user guide, is 0.55 W/kg. The SAR value for this product in its data transmission mode (body-worn use) is 0.31 W/kg. (Body-worn measurements differ among phone models, depending upon available accessories and regulatory requirements).²

While there may be differences between the SAR levels of various phones and at various positions, they all meet the governmental requirements for safe exposure. Please note that improvements to this product model could cause differences in the SAR value for later products; in all cases, products are designed to be within the guidelines.

Additional information on Specific Absorption Rates (SAR) can be found on the Cellular Telecommunications & Internet Association (CTIA) Web site:

<http://www.phonefacts.net>

or the Canadian Wireless Telecommunications Association (CWTA) Web site:

<http://www.cwta.ca>

1. In the United States and Canada, the SAR limit for mobile phones used by the public is 1.6 watts/kg (W/kg) averaged over one gram of tissue. The standard incorporates a substantial margin of safety to give additional protection for the public and to account for any variations in measurements.
2. The SAR information includes the Motorola testing protocol, assessment procedure, and measurement uncertainty range for this product.

European Union Directives Conformance Statement



Hereby, Motorola declares that this product is in compliance with

- The essential requirements and other relevant provisions of Directive 1999/5/EC
- All other relevant EU Directives

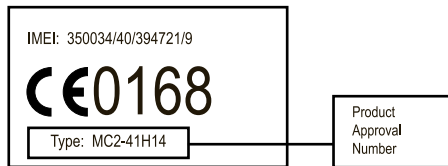

The above gives an example of a typical Product Approval Number.

You can view your product's Declaration of Conformity (DoC) to Directive 1999/5/EC (to R&TTE Directive) at www.motorola.com/rtte. To find your DoC, enter the product Approval Number from your product's label in the "Search" bar on the web site.



MOTOROLA

Important Safety and Legal Information

Safety and General Information

This section contains important information on the safe and efficient operation of your mobile device. Read this information before using your mobile device.*

Exposure to Radio Frequency (RF) Energy

Your mobile device contains a transmitter and receiver. When it is ON, it receives and transmits RF energy. When you communicate with your mobile device, the system handling your call controls the power level at which your mobile device transmits.

Your Motorola mobile device is designed to comply with local regulatory requirements in your country concerning exposure of human beings to RF energy.

Operational Precautions

For optimal mobile device performance and to be sure that human exposure to RF energy does not exceed the guidelines set forth in

* The information provided in this document supersedes the general safety information in user's guides published prior to May 1, 2007.

the relevant standards, always follow these instructions and precautions.

External Antenna Care

If your mobile device has an external antenna, use only a Motorola-supplied or approved replacement antenna. Use of unauthorized antennas, modifications, or attachments could damage the mobile device and/or may result in your device not complying with local regulatory requirements in your country.

DO NOT hold the external antenna when the mobile device is IN USE. Holding the external antenna affects call quality and may cause the mobile device to operate at a higher power level than needed.

Product Operation

When placing or receiving a phone call, hold your mobile device just like you would a landline phone.

If you wear the mobile device on your body, always place the mobile device in a Motorola-supplied or approved clip, holder, holster, case, or body harness. If you do not use a body-worn accessory supplied or approved by Motorola—or if you hang your mobile device from a lanyard around your neck—keep the mobile

device and its antenna at least 2.5 centimeters (1 inch) from your body when transmitting.

When using any data feature of the mobile device, with or without an accessory cable, position the mobile device and its antenna at least 2.5 centimeters (1 inch) from your body.

Using accessories not supplied or approved by Motorola may cause your mobile device to exceed RF energy exposure guidelines. For a list of Motorola-supplied or approved accessories, visit our Web site at: www.motorola.com.

RF Energy Interference/Compatibility

Nearly every electronic device is subject to RF energy interference from external sources if inadequately shielded, designed, or otherwise configured for RF energy compatibility. In some circumstances your mobile device may cause interference with other devices.

Follow Instructions to Avoid Interference Problems

Turn off your mobile device in any location where posted notices instruct you to do so.

In an aircraft, turn off your mobile device whenever instructed to do so by airline staff. If your mobile device offers an airplane mode or similar feature, consult airline staff about using it in flight.

Implantable Medical Devices

If you have an implantable medical device, such as a pacemaker or defibrillator, consult your physician before using this mobile device.

Persons with implantable medical devices should observe the following precautions:

- ALWAYS keep the mobile device more than 20 centimeters (8 inches) from the implantable medical device when the mobile device is turned ON.
- DO NOT carry the mobile device in the breast pocket.
- Use the ear opposite the implantable medical device to minimize the potential for interference.
- Turn OFF the mobile device immediately if you have any reason to suspect that interference is taking place.

Read and follow the directions from the manufacturer of your implantable medical device. If you have any questions about using your mobile device with your implantable medical device, consult your health care provider.

Driving Precautions

Check the laws and regulations on the use of mobile devices in the area where you drive. Always obey them.

When using your mobile device while driving, please:

- Give full attention to driving and to the road. Using a mobile device may be distracting. Discontinue use if you can't concentrate on driving.
- Use handsfree operation, if available.
- Pull off the road and park before making or answering a call if driving conditions so require.
- Do not place a mobile device in the airbag deployment area.

Responsible driving practices can be found in the “Smart Practices While Driving” section in this user’s guide and/or at the Motorola Web site: www.motorola.com/callsmart.

Note: The use of wireless phones while driving may cause distraction. Discontinue a call if you can't concentrate on driving. Additionally, the use of wireless devices and their accessories may be prohibited or restricted in certain areas. Always obey the laws and regulations on the use of these products.

Operational Warnings

Obey all posted signs when using mobile devices in public areas.







Potentially Explosive Atmospheres

Areas with potentially explosive atmospheres are often but not always posted and can include fueling areas such as below decks on boats, fuel or chemical transfer or storage facilities, or areas where the air contains chemicals or particles, such as grain dust, or metal powders.

When you are in such an area, turn off your mobile device, and do not remove, install, or charge batteries. In such areas, sparks can occur and cause an explosion or fire.

Symbol Key

Your battery, charger, or mobile device may contain symbols, defined as follows:

Symbol	Definition
	Important safety information follows.
	Do not dispose of your battery or mobile device in a fire.
	Your battery or mobile device may require recycling in accordance with local laws. Contact your local regulatory authorities for more information.
	Do not throw your battery or mobile device in the trash.
	Your mobile device contains an internal lithium ion battery.
	Do not let your battery, charger, or mobile device get wet.

Symbol	Definition
	Listening at full volume to music or voice through a headset may damage your hearing.

Batteries and Chargers

Caution: Improper treatment or use of batteries may present a danger of fire, explosion, leakage, or other hazard. For more information, see the “Battery Use & Battery Safety” section in this user’s guide.

Choking Hazards

Your mobile device or its accessories may include detachable parts, which may present a choking hazard to small children. Keep your mobile device and its accessories away from small children.

Glass Parts

Some parts of your mobile device may be made of glass. This glass could break if the product is dropped on a hard surface or receives a substantial impact. If glass breaks, do not touch or attempt to remove. Stop using your mobile device until the glass is replaced by a qualified service center.

Seizures/Blackouts

Some people may be susceptible to epileptic seizures or blackouts when exposed to flashing lights, such as when playing video games. These may occur even if a person has never had a previous seizure or blackout.

If you have experienced seizures or blackouts, or if you have a family history of such occurrences, please consult with your physician before playing video games or enabling a flashing-lights feature (if available) on your mobile device.

Discontinue use and consult a physician if any of the following symptoms occur: convulsion, eye or muscle twitching, loss of awareness, involuntary movements, or disorientation. It is always a good idea to hold the screen away from your eyes, leave the lights on in the room, take a 15-minute break every hour, and stop use if you are very tired.

Caution About High Volume Usage



Listening at full volume to music or voice through a headset may damage your hearing.

Repetitive Motion

When you repetitively perform actions such as pressing keys or entering finger-written characters, you may experience occasional discomfort in your hands, arms, shoulders, neck, or other parts of

your body. If you continue to have discomfort during or after such use, stop use and see a physician.

Industry Canada Notice to Users

Operation is subject to the following two conditions: (1) This device may not cause interference and (2) This device must accept any interference, including interference that may cause undesired operation of the device. See RSS-GEN 7.1.5.

FCC Notice to Users

The following statement applies to all products that have received FCC approval. Applicable products bear the FCC logo, and/or an FCC ID in the format FCC-ID:xxxxxx on the product label.

Motorola has not approved any changes or modifications to this device by the user. Any changes or modifications could void the user's authority to operate the equipment. See 47 CFR Sec. 15.21.

This device complies with part 15 of the FCC Rules. Operation is subject to the following two conditions: (1) This device may not cause harmful interference, and (2) this device must accept any interference received, including interference that may cause undesired operation. See 47 CFR Sec. 15.19(3).

This equipment has been tested and found to comply with the limits for a Class B digital device, pursuant to part 15 of the FCC Rules. These limits are designed to provide reasonable protection against harmful interference in a residential installation. This equipment generates, uses and can radiate radio frequency energy and, if not installed and used in accordance with the instructions, may cause harmful interference to radio communications. However, there is no guarantee that interference will not occur in a particular installation. If this equipment does cause harmful interference to radio or television reception, which can be determined by turning the equipment off and on, the user is

encouraged to try to correct the interference by one or more of the following measures:

- Reorient or relocate the receiving antenna.
- Increase the separation between the equipment and the receiver.
- Connect the equipment to an outlet on a circuit different from that to which the receiver is connected.
- Consult the dealer or an experienced radio/TV technician for help.

Motorola Limited Warranty for the United States and Canada

What Does this Warranty Cover?

Subject to the exclusions contained below, Motorola, Inc. warrants its telephones, pagers, messaging devices, and consumer and professional two-way radios (excluding commercial, government or industrial radios) that operate via Family Radio Service or General Mobile Radio Service, Motorola-branded or certified accessories sold for use with these Products ("Accessories") and Motorola software contained on CD-ROMs or other tangible media and sold for use with these Products ("Software") to be free from defects in materials and workmanship under normal consumer usage for the period(s) outlined below. This limited warranty is a consumer's exclusive remedy, and applies as follows to new Motorola Products, Accessories and Software purchased by consumers in the United States or Canada, which are accompanied by this written warranty:

Products and Accessories

Products Covered	Length of Coverage
Products and Accessories as defined above, unless otherwise provided for below.	One (1) year from the date of purchase by the first consumer purchaser of the product unless otherwise provided for below.
Decorative Accessories and Cases. Decorative covers, bezels, PhoneWrap™ covers and cases.	Limited lifetime warranty for the lifetime of ownership by the first consumer purchaser of the product.
Monaural Headsets. Ear buds and boom headsets that transmit mono sound through a wired connection.	Limited lifetime warranty for the lifetime of ownership by the first consumer purchaser of the product.

Products Covered	Length of Coverage
Consumer and Professional Two-Way Radio Accessories.	Ninety (90) days from the date of purchase by the first consumer purchaser of the product.
Products and Accessories that are Repaired or Replaced.	The balance of the original warranty or for ninety (90) days from the date returned to the consumer, whichever is longer.

Exclusions

Normal Wear and Tear. Periodic maintenance, repair and replacement of parts due to normal wear and tear are excluded from coverage.

Batteries. Only batteries whose fully charged capacity falls below 80% of their rated capacity and batteries that leak are covered by this limited warranty.

Abuse & Misuse. Defects or damage that result from: (a) improper operation, storage, misuse or abuse, accident or neglect, such as physical damage (cracks, scratches, etc.) to the surface of the product resulting from misuse; (b) contact with liquid, water, rain, extreme humidity or heavy perspiration, sand, dirt or the like, extreme heat, or food; (c) use of the Products or Accessories for commercial purposes or subjecting the Product or Accessory to abnormal usage or conditions; or (d) other acts which are not the fault of Motorola, are excluded from coverage.

Use of Non-Motorola Products and Accessories. Defects or damage that result from the use of Non-Motorola branded or certified Products, Accessories, Software or other peripheral equipment are excluded from coverage.

Unauthorized Service or Modification. Defects or damages resulting from service, testing, adjustment, installation, maintenance, alteration, or modification in any way by someone other than Motorola, or its authorized service centers, are excluded from coverage.

Altered Products. Products or Accessories with (a) serial numbers or date tags that have been removed, altered or obliterated; (b) broken seals or that show evidence of tampering; (c) mismatched board serial numbers; or (d) nonconforming or non-Motorola housings, or parts, are excluded from coverage.

Communication Services. Defects, damages, or the failure of Products, Accessories or Software due to any communication service or signal you may subscribe to or use with the Products Accessories or Software is excluded from coverage.

Software

Products Covered	Length of Coverage
Software. Applies only to physical defects in the media that embodies the copy of the software (e.g. CD-ROM, or floppy disk).	Ninety (90) days from the date of purchase.

Exclusions

Software Embodied in Physical Media. No warranty is made that the software will meet your requirements or will work in combination with any hardware or software applications provided by third parties, that the operation of the software products will be uninterrupted or error free, or that all defects in the software products will be corrected.

Software NOT Embodied in Physical Media. Software that is not embodied in physical media (e.g. software that is downloaded from the internet), is provided “as is” and without warranty.

Who Is Covered?

This warranty extends only to the first consumer purchaser, and is not transferable.

What Will Motorola Do?

Motorola, at its option, will at no charge repair, replace or refund the purchase price of any Products, Accessories or Software that does not conform to this warranty. We may use functionally equivalent reconditioned/refurbished/pre-owned or new Products, Accessories or parts. No data, software or applications added to your Product, Accessory or Software, including but not limited to personal contacts, games and ringer tones, will be reinstalled. To avoid losing such data, software and applications please create a back up prior to requesting service.

How to Obtain Warranty Service or Other Information

USA	Phones 1-800-331-6456 Pagers 1-800-548-9954 Two-Way Radios and Messaging Devices 1-800-353-2729
Canada	All Products 1-800-461-4575
TTY	1-888-390-6456
For Accessories and Software , please call the telephone number designated above for the product with which they are used.	

You will receive instructions on how to ship the Products, Accessories or Software, at your expense, to a Motorola Authorized Repair Center. To obtain service, you must include: (a) a copy of your receipt, bill of sale or other comparable proof of purchase; (b) a written description of the problem; (c) the name of your service provider, if applicable; (d) the name and location of the installation facility (if applicable) and, most importantly; (e) your address and telephone number.

What Other Limitations Are There?

ANY IMPLIED WARRANTIES, INCLUDING WITHOUT LIMITATION THE IMPLIED WARRANTIES OF MERCHANTABILITY AND FITNESS FOR A PARTICULAR PURPOSE, SHALL BE LIMITED TO THE DURATION OF THIS LIMITED WARRANTY, OTHERWISE THE REPAIR, REPLACEMENT, OR REFUND AS PROVIDED UNDER THIS EXPRESS LIMITED WARRANTY IS THE EXCLUSIVE REMEDY OF THE CONSUMER, AND IS PROVIDED IN LIEU OF ALL OTHER WARRANTIES, EXPRESS OR IMPLIED. IN NO EVENT SHALL MOTOROLA BE LIABLE, WHETHER IN CONTRACT OR TORT (INCLUDING NEGLIGENCE) FOR DAMAGES IN EXCESS OF THE PURCHASE PRICE OF THE PRODUCT, ACCESSORY OR SOFTWARE, OR FOR ANY INDIRECT, INCIDENTAL, SPECIAL OR CONSEQUENTIAL DAMAGES OF ANY KIND, OR LOSS OF REVENUE OR PROFITS, LOSS OF BUSINESS, LOSS OF INFORMATION OR DATA, SOFTWARE OR APPLICATIONS OR OTHER FINANCIAL LOSS ARISING OUT OF OR IN CONNECTION WITH THE ABILITY OR INABILITY TO USE THE PRODUCTS, ACCESSORIES OR SOFTWARE TO THE FULL EXTENT THESE DAMAGES MAY BE DISCLAIMED BY LAW.

Some states and jurisdictions do not allow the limitation or exclusion of incidental or consequential damages, or limitation on the length of an implied warranty, so the above limitations or exclusions may not apply to you. This warranty gives you specific legal rights, and you may also have other rights that vary from state to state or from one jurisdiction to another.

Laws in the United States and other countries preserve for Motorola certain exclusive rights for copyrighted Motorola software such as the exclusive rights to reproduce and distribute copies of the Motorola software. Motorola software may only be copied into, used in, and redistributed with, the Products associated with such Motorola software. No other use, including without limitation disassembly of such Motorola software or exercise of the exclusive rights reserved for Motorola, is permitted.

Hearing Aid Compatibility with Mobile Phones

Some Motorola phones are measured for compatibility with hearing aids. If the box for your particular model has “Rated for Hearing Aids” printed on it, the following explanation applies.

When some mobile phones are used near some hearing devices (hearing aids and cochlear implants), users may detect a buzzing, humming, or whining noise. Some hearing devices are more immune than others to this interference noise, and phones also vary in the amount of interference they generate.

The wireless telephone industry has developed ratings for some of their mobile phones, to assist hearing device users in finding phones that may be compatible with their hearing devices. Not all phones have been rated. Phones that are rated have the rating on their box or a label on the box.

The ratings are not guarantees. Results will vary depending on the user’s hearing device and hearing loss. If your hearing device happens to be vulnerable to interference, you may not be able to use a rated phone successfully. Trying out the phone with your hearing device is the best way to evaluate it for your personal needs.

M-Ratings: Phones rated M3 or M4 meet FCC requirements and are likely to generate less interference to hearing devices than phones that are not labeled. M4 is the better/higher of the two ratings.

T-Ratings: Phones rated T3 or T4 meet FCC requirements and are likely to be more usable with a hearing device’s telecoil (“T Switch” or “Telephone Switch”) than unrated phones. T4 is the better/higher of the two ratings. (Note that not all hearing devices have telecoils in them.)

Hearing devices may also be measured for immunity to this type of interference. Your hearing device manufacturer or hearing health professional may help you find results for your hearing device. The more immune your hearing aid is, the less likely you are to experience interference noise from mobile phones.

Information from the World Health Organization

Present scientific information does not indicate the need for any special precautions for the use of mobile phones. If you are concerned, you may want to limit your own or your children's RF

exposure by limiting the length of calls or by using handsfree devices to keep mobile phones away from your head and body.

Source: WHO Fact Sheet 193

Further information: <http://www.who.int/peh-emf>

Product Registration

Online Product Registration:

direct.motorola.com/hellomoto/Motosupport/source/registration.asp

Product registration is an important step toward enjoying your new Motorola product. Registering helps us facilitate warranty service, and permits us to contact you should your product require an update or other service. Registration is for U.S. residents only and is not required for warranty coverage.

Please retain your original dated sales receipt for your records. For warranty service of your Motorola Personal Communications Product you will need to provide a copy of your dated sales receipt to confirm warranty status.

Thank you for choosing a Motorola product.

Export Law Assurances

This product is controlled under the export regulations of the United States of America and Canada. The Governments of the United States of America and Canada may restrict the exportation

or re-exportation of this product to certain destinations. For further information contact the U.S. Department of Commerce or the Canadian Department of Foreign Affairs and International Trade.

Caring for the Environment by Recycling



This symbol on a Motorola product means the product should not be disposed of with household waste.

Disposal of your Mobile Device and Accessories

Please do not dispose of mobile devices or electrical accessories (such as chargers, headsets, or batteries) with your household waste. These items should be disposed of in accordance with the national collection and recycling schemes operated by your local or regional authority. Alternatively, you may return unwanted mobile devices and electrical accessories to any Motorola Approved Service Center in your region. Details of Motorola approved

national recycling schemes, and further information on Motorola recycling activities can be found at: www.motorola.com/recycling

Disposal of your Mobile Device Packaging and User's Guide

Product packaging and user's guides should only be disposed of in accordance with national collection and recycling requirements. Please contact your regional authorities for more details.

California Perchlorate Label

Some mobile phones use an internal, permanent backup battery on the printed circuit board that may contain very small amounts of perchlorate. In such cases, California law requires the following label:

“Perchlorate Material – special handling may apply. See www.dtsc.ca.gov/hazardouswaste/perchlorate.”

There is no special handling required by consumers.

Privacy and Data Security

Motorola understands that privacy and data security are important to everyone. Because some features of your mobile device may affect your privacy or data security, please follow these recommendations to enhance protection of your information:

- **Monitor access**—Keep your mobile device with you and do not leave it where others may have unmonitored access. Lock your device's keypad where this feature is available.
- **Keep software up to date**—If Motorola or a software/application vendor releases a patch or software fix for your mobile device which updates the device's security, install it as soon as possible.
- **Erase before recycling**—Delete personal information or data from your mobile device prior to disposing of it or turning it in for recycling. For step-by-step instructions on how to delete all personal information from your device, see the section entitled "master clear" or "delete data" in this user's guide.

Note: For information on backing up your mobile device data before erasing it, go to www.motorola.com and then navigate to the "downloads" section of the consumer Web page for "Motorola Backup" or "Motorola Phone Tools."

- **Understanding AGPS**—In order to comply with emergency caller location requirements of the FCC, certain Motorola mobile devices incorporate *Assisted Global Positioning System* (AGPS) technology. AGPS technology also can be used in non-emergency applications to track and monitor a user's location—for example, to provide driving directions. Users who prefer not to permit such tracking and monitoring should avoid using such applications.

If you have further questions regarding how use of your mobile device may impact your privacy or data security, please contact Motorola at privacy@motorola.com, or contact your service provider.

Smart Practices While Driving

Drive Safe, Call SmartSM

Check the laws and regulations on the use of mobile devices and their accessories in the areas where you drive. Always obey them. The use of these devices may be prohibited or restricted in certain areas. Go to www.motorola.com/callsmart for more information.

Your mobile device lets you communicate by voice and data—almost anywhere, anytime, wherever wireless service is available and safe conditions allow. When driving a car, driving is your first responsibility. If you choose to use your mobile device while driving, remember the following tips:

- **Get to know your Motorola mobile device and its features such as speed dial and redial.** If available, these features help you to place your call without taking your attention off the road.
- **When available, use a handsfree device.** If possible, add an additional layer of convenience to your mobile device with one of the many Motorola Original handsfree accessories available today.
- **Position your mobile device within easy reach.** Be able to access your mobile device without removing your eyes from the road. If you receive an incoming call at an



inconvenient time, if possible, let your voice mail answer it for you.

- **Let the person you are speaking with know you are driving; if necessary, suspend the call in heavy traffic or hazardous weather conditions.** Rain, sleet, snow, ice, and even heavy traffic can be hazardous.
- **Do not take notes or look up phone numbers while driving.** Jotting down a “to do” list or going through your address book takes attention away from your primary responsibility—driving safely.
- **Dial sensibly and assess the traffic; if possible, place calls when your car is not moving or before pulling into traffic.** If you must make a call while moving, dial only a few numbers, check the road and your mirrors, then continue.
- **Do not engage in stressful or emotional conversations that may be distracting.** Make people you are talking with aware you are driving and suspend conversations that can divert your attention away from the road.
- **Use your mobile device to call for help.** Dial 911 or other local emergency number in the case of fire, traffic accident, or medical emergencies.*

- **Use your mobile device to help others in emergencies.** If you see an auto accident, crime in progress, or other serious emergency where lives are in danger, call 911 or other local emergency number, as you would want others to do for you.*
- **Call roadside assistance or a special non-emergency wireless assistance number when necessary.** If you see a broken-down vehicle posing no serious hazard, a broken traffic signal, a minor traffic accident where no one appears injured, or a vehicle you know to be stolen, call roadside assistance or other special non-emergency wireless number.*

* Wherever wireless phone service is available.

index

A

- accessories 9, 71
- accessory connector port 1
- activation list 79
- active line indicator 34
- active line, changing 58
- ActiveSync 72, 73
- airplane mode 81
- alarm clock 74
- alert
 - set 39, 44, 45
 - turn off 39, 50
- answer a call 13, 49
- attach a number 51, 55
- audio player 18

B

- backlight 47
- battery 10, 11
 - extending battery life 11
- battery indicator 34
- battery life, extending 46, 47
- Bluetooth connection
 - calendar entry, printing 76
 - calendar entry, sending 75
 - contacts entries 64
 - copy files 16
 - description 15
 - make phone discoverable 16
 - messages, printing 67
 - printing 18
 - receive files 17
 - turn power on 15

- use headset or handsfree car kit 16

- brightness 47
- browser messages 68
- browser. See micro-browser

C

- cables 29
- calculator 76
- calendar 74, 75
- call
 - answering 13, 49
 - barring 57
 - end 13
 - ending 13
 - forwarding 57
 - making 13

- timers 70
- waiting 56
- call forward indicator 34
- call history 50
- caller ID 51, 53, 61
- camera 20
- car kit 71
- categories 62, 63
- center key 1, 39
- center select key 9
- certificate management 77
- clock 45
- codes 42, 43
- conference call 57
- contacts 51, 55, 59, 60
- copy files 16
- copyrighted files, activating 79
- costs, tracking 70

D

- data call 71, 72

- data indicator 33
- date, setting 45
- delayed answer 50
- dial a phone number 13, 58, 59
- diald calls 50
- digital audio 18
- display 2, 32, 47
- downloaded files
 - activating 79
 - from Web pages 79
 - in messages 66
 - storage location 79
- drafts folder 27
- DTMF tones 51, 59

E

- earpiece volume 39
- EDGE indicator 33
- email
 - reading and managing 66
 - sending 65

- settings 68
- emergency number 53
- end a call 13
- end key 1, 13
- Enter Unlock Code message 42
- export regulations 101
- external display 23, 42

F

- fax call 52, 71, 72
- fixed dial 58
- flip 13, 49
- forward calls 57

G

- games 80
- GPRS indicator 33
- group mailing list 63

H

- handsfree speaker 42

headset 71
headset jack 1
hearing aids 99
hold a call 56
home screen 2, 32, 48

I

in-call indicator 34
Incoming Call message 53
information services 68
international access code 56
iTAP text entry mode 36

J

Java applications 80
Java indicator 34

K

keypad 49, 69

L

language 68
linking. See Bluetooth connection
lock
 application 77
 phone 43
 SIM card 77
Low Battery message 34

M

make a call 13
master clear 70
master reset 69
memory card 28
menu 2, 9, 32, 48, 69
menu icons 32, 48
message 65, 66, 67
message indicator 27, 34
message reminders 69
micro-browser 68, 78, 80

Missed Calls message 52
MMS, defined 26
MOTOSYNC 72, 73
MP3 audio files 18, 19
multimedia message 26, 65, 66,
 67
music 78
mute a call 56

N

navigation key 1, 9, 39
network settings 73
notepad 55
number. See phone number
numeric entry mode 38

O

object exchange 16
1-touch dial 60
open to answer 49
optional accessory 9

optional feature 9

P

pairing. See Bluetooth connection

passwords. See codes

perchlorate label 102

personalize 68

phone number 14, 58

photo 20

picture ID 53, 61

PIN code 12, 42, 77

PIN2 code 42

power key 1, 12, 13

printing 18

Q

quick dial 59

R

received calls 50

redial 52

reminders 69

restrict calls 57

return a call 52

ring style indicator 34

ring style, setting 39, 44

ring tone 78

ringer ID 53, 61, 69

ringer volume 39, 69

roam indicator 33

S

safety information 88

safety tips 104

screen saver 46

scrolling 69

security code 42

send key 1, 13

service dial 58

signal strength indicator 33

silent answer 50

SIM Blocked message 12, 77

SIM card 10, 12, 42, 58, 67, 77

skin 47

soft keys 1, 32, 48

software update 73

speakerphone 71

speed dial 59, 60

store your number 14

streaming video 79

symbol entry mode 38

synchronizing 72, 73

T

talking phone 44

tap text entry mode 37

telephone number. See phone
number

text entry 35

text marquee 69

text message 66, 67

theme 46

time zone 45

time, setting 45
timers 70
transfer a call 57
TTY device 58
turn on/off 12

U

unlock
 application 77
 phone 12, 42, 43
 SIM card 77
unlock code 42, 43
USB cables 29

V

video clip 26
videos 24, 79
voice commands 39
voice dial 39, 71
voice message 65
voice record 76

110 index

voicemail 54
voicemail message indicator 34,
 54
volume 39, 69

W

wallpaper 46
warranty 95
Web pages 78
Web sessions 80
WHO information 100

Y

your phone number 14

U.S. patent Re. 34,976

www.motorola.com



MOTOROLA

