

OmniStar GX2

GX2-EM1000 Series

1550nm Broadcast Transmitter

Benefits Include:

- Provides full performance 50 – 1002 MHz forward bandwidth.
- Designed for combination analog/digital operation
- SBS suppression up to +20 dBm for PON applications
- Test point for RF input
- CTB optimization loop
- Low RF Input Level: +17dBmV
- Link distances up to 100km
- Automatic Gain Control (AGC)
- RoHS Compliant
- Compatible with GX2-HSG platform

The OmniStar® GX2-EM1000 series of 1550nm Broadcast Transmitters uses advanced optical linearization technology to provide low noise and superior distortion performance. The suite of products satisfies various applications: full band loading or split band loading, super-trunking or distribution to nodes, long-distance transport or short hops. Also, each version (tab) of the transmitters is optimized for transmission system standards with either 6 MHz, 7 MHz, or 8 MHz video channels.

A proprietary technique is used to provide Stimulated Brillouin Scattering (SBS) suppression up to +20dBm. This feature is important when used in conjunction with optical amplifiers in order to overcome splitter and combiner losses associated with PON architectures. The transmitter uses a 1550nm DFB laser diode as a precision light source, which is modulated by an optically linearized Mach Zehnder modulator. Use of external modulation technology eliminates laser chirp and allows designs of transport systems for distances up to 100 kilometers.

Enhanced with a high-performance internal microprocessor, the EM1000 series transmitter is continuously monitored while a sophisticated control algorithm assures optimum performance.

SYSTEM APPLICATIONS

Supertrunking

The EM1000 transmitter, operating in conjunction with OmniStar GX2 optical amplifiers (OA), provides an effective solution for supertrunks. With SBS suppression available at 16dBm, links up to 65km can be met with one OA. Longer links can be supported with multiple OAs while maintaining superior performance.

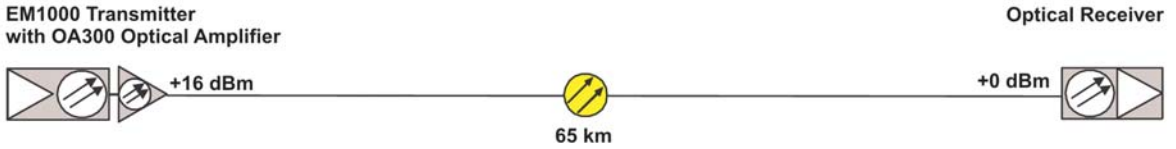

Distribution to Nodes

Used with OmniStar GX2 optical amplifiers (OAs) or Motorola's other high output power OAs, the EM1000 transmitter can serve a large number of optical nodes. With an optical coupler network and remote OAs, the EM1000 can satisfy an endless combination of nodes and distances.

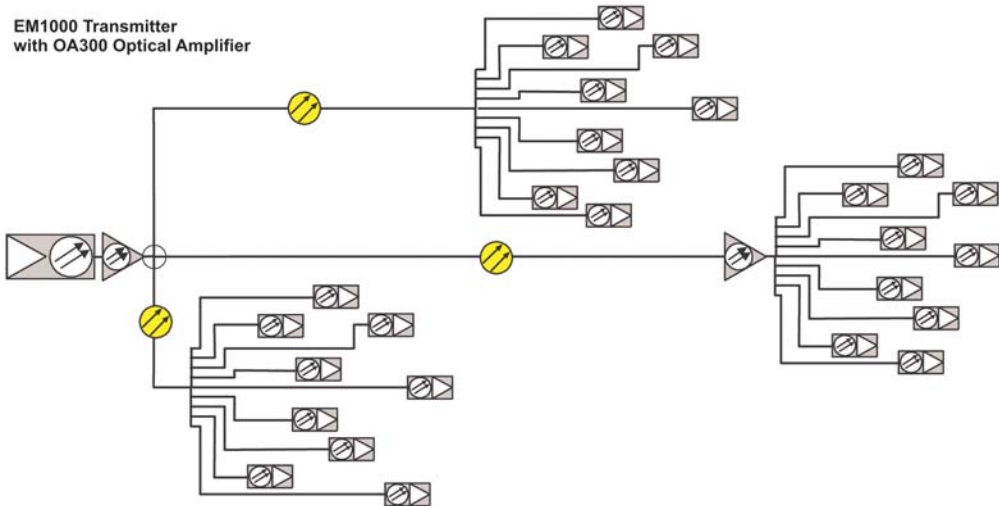

Split-Band Supertrunk

To get even better noise performance on a supertrunk, the EM325C and EM550C can be used to split the broadcast signal. The RF signals are split and fed into the transmitters. EM325C transmits the signals in the lower band and the EM550C transmits the signal in the higher band. The signals can then be re-combined at the receiving location. If fiber constrained, the split band optical signals can be wavelength division multiplexed onto a single fiber.

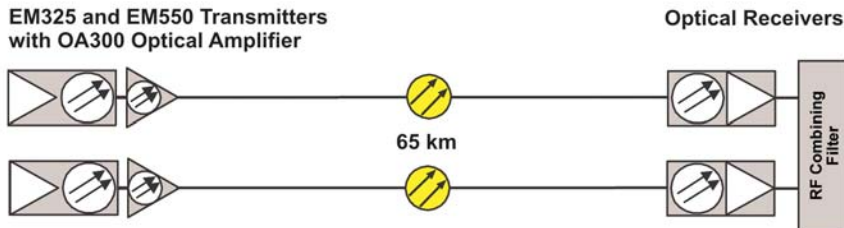

SYSTEM APPLICATIONS, CONTINUED

Short-Hop

The EM1000 transmitter is available in optical power at +10dBm. This higher-powered transmitter can transport up to 35km without the use of an optical amplifier, providing a cost-effective supertrunk solution.

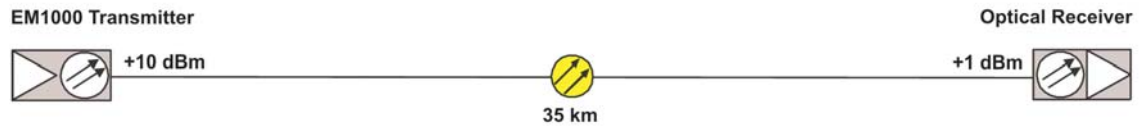

PON

The EM1000 transmitter is also available in a high SBS suppression version for PON applications. This transmitter supports launch powers up to +20dBm, which may be required to overcome splitter and combiner losses associated with some PON architectures, when used in conjunction with Motorola's N2U-OA300 series of optical amplifiers.

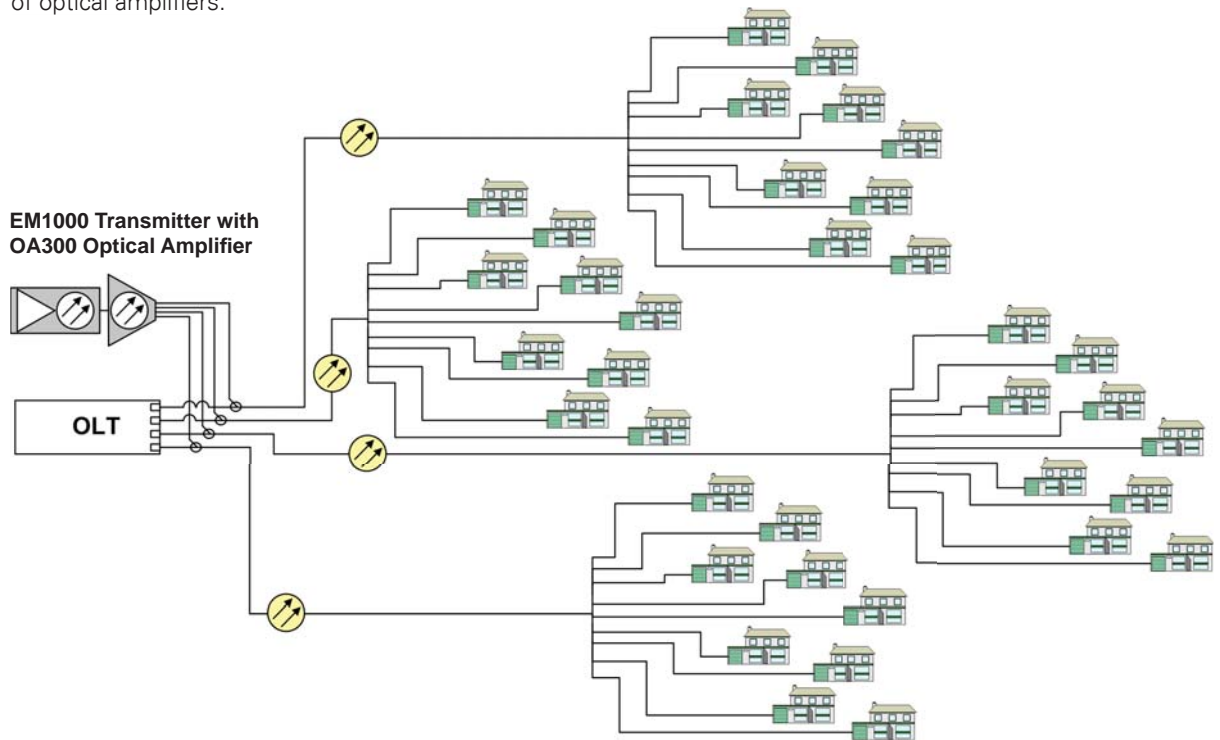

PERFORMANCE

	EM1000C7/16 EM1000C7/16B	EM1000C7/13	EM1000C10/11	EM1000C8/20
Carrier-to-Noise Ratio				
79 NTSC Channels + 320MHz Digital	52.5 dB	49.5 dB	54.5 dB	48.5 dB
65 PAL B/G Channels + 264 MHz Digital	51.5 dB	48.5 dB	53.5 dB	47.5 dB
61 PAL D/K Channels + 264 MHz Digital	51.5 dB	48.5 dB	53.5 dB	47.5 dB
Composite Second Order	-66 dBc	-66 dBc	-65 dBc	-60 dBc
Composite Triple Beat	-66 dBc	-66 dBc	-65 dBc	-60 dBc
Distortion Test Conditions	Notes 1, 6	Notes 2, 6	Notes 3, 6	Notes 4, 6

	EM325C7/13	EM550C7/13	EM325C7/16	EM550C7/16
Carrier-to-Noise Ratio				
40 NTSC Channels	53.0 dB	53.0 dB	56.0 dB	56.0 dB
32 PAL B/G Channels	52.0 dB	52.0 dB	55.5 dB	55.5 dB
29 PAL D/K Channels	52.0 dB	52.0 dB	55.5 dB	55.5 dB
Composite Second Order	-68 dBc	-68 dBc	-68 dBc	-68 dBc
Composite Triple Beat	-66 dBc	-66 dBc	-66 dBc	-66 dBc
Distortion Test Conditions	Notes 2, 5	Notes 2, 5	Notes 1, 5	Notes 1, 5

Notes

1. Measured through 65km fiber with +16 dBm EDFA into optical receiver at 0 dBm.
2. Measured through 100km fiber with +13 dBm EDFA into optical receiver at 0 dBm.
3. Measured through 35km fiber into optical receiver at 0 dBm.
4. Measured through 20km fiber into optical receiver at -5 dBm.
5. Measured with split band loading: EM325 loaded from 50–325MHz and EM550 from 325–550MHz.
6. All CNR performance levels are ~0.5 dB worse when using 1002MHz loading.

Measurements are typical and made at room temperature with a GX2-RX1000 optical receiver.

Model Number*	Description
GX2-EM1000C7/16	1550nm Broadcast Tx, 1 GHz, full band,1544–1548nm, +7dBm output, SBS suppression +16dBm minimum
GX2-EM1000C7/16B	1550nm Broadcast Tx, 1 GHz, full band,1555–1560nm, +7dBm output, SBS suppression +16dBm minimum
GX2-EM1000C7/13	1550nm Broadcast Tx, 1 GHz, full band,1544–1548nm, +7dBm output, SBS suppression +13dBm minimum
GX2-EM1000C10/11	1550nm Broadcast Tx, 1 GHz, full band,1544–1548nm, +10dBm output, SBS suppression +11dBm minimum
GX2-EM1000C8/20	1550nm Broadcast Tx, 1 GHz, full band PON 20km,1550–1554nm, +8dBm output, SBS suppression +20dBm minimum
GX2-EM325C7/13	1550nm Broadcast Tx,1 GHz, split band low,1544–1548nm, +7dBm output, SBS suppression +13dBm minimum
GX2-EM550C7/13	1550nm Broadcast Tx,1 GHz, split band high,1555–1560nm, +7dBm output, SBS suppression +13dBm minimum
GX2-EM325C7/16	1550nm Broadcast Tx,1 GHz, split band low,1544–1548nm, +7dBm output, SBS suppression +16dBm minimum
GX2-EM550C7/16	1550nm Broadcast Tx,1 GHz, split band high,1555–1560nm, +7dBm output, SBS suppression +16dBm minimum

*SC/APC optical connector is standard. Add /E to designate E2000 optical connector.

SPECIFICATIONS

OPTICAL

EM1000C7/16	
Center Wavelength	1546 ± 2.0nm
Optical Output Power (min)	+7 dBm
SBS Suppression (min)	+16 dBm
EM1000C7/16B	
Center Wavelength	1557.5 ± 2.5nm
Optical Output Power (min)	+7 dBm
SBS Suppression (min)	+16 dBm
EM1000C7/13	
Center Wavelength	1546 ± 2.0nm
Optical Output Power (min)	+7 dBm
SBS Suppression (min)	+13 dBm
EM1000C10/11	
Center Wavelength	1546 ± 2.0nm
Optical Output Power (min)	+9.5 dBm
SBS Suppression (min)	+11 dBm
EM1000C8/20	
Center Wavelength	1552 ± 2.0nm
Optical Output Power (min)	+8 dBm
SBS Suppression (min)	+20 dBm
EM325C7/13	
Center Wavelength	1546 ± 2.0nm
Optical Output Power (min)	+7 dBm
SBS Suppression (min)	+13 dBm
EM550C7/13	
Center Wavelength	1557.5 ± 2.5nm
Optical Output Power (min)	+7 dBm
SBS Suppression (min)	+13 dBm
EM325C7/16	
Center Wavelength	1546 ± 2.0nm
Optical Output Power (min)	+7 dBm
SBS Suppression (min)	+16 dBm
EM550C7/16	
Center Wavelength	1557.5 ± 2.5nm
Optical Output Power (min)	+7 dBm
SBS Suppression (min)	+16 dBm

RF

Operational Bandwidth	47 – 1002 MHz
RF Input Level	
79 NTSC, 64 PAL B/G, 58 PAL D/K	17 ± 1 dBmV
40 NTSC, 32 PAL B/G, 29 PAL D/K	19 ± 1 dBmV
Frequency Response	
47 – 750MHz	± 0.5 dB
47 – 1002MHz	± 0.75 dB
RF Input Test Point	-20±0.5 dB, relative to input RF level

ELECTRICAL/ENVIRONMENTAL/MECHANICAL

Dimensions	3-wide module, 3" W X 5.9" H X 15" D (7.5 cm X 15 cm X 38 cm)
Weight	6.8 lbs. (3.0 kg)
Mounting	GX2-HSG* Equipment Shelf
Operating Temperature Range	32°F to 122°F (0°C to 50°C)
RF Connector Types	
Input	F-type (using G-to-F adaptor on chassis)
Test point	F-type
Storage Temperature Range	-40°F to 185°F (-40°C to 85°C)

Specifications are subject to change without notice.



Motorola, Inc., 101 Tournament Drive, Horsham, Pennsylvania 19044 U.S.A. www.motorola.com

MOTOROLA and the Stylized M logo are registered in the US Patent & Trademark Office. All other product or service names are property of their respective owners.
 © Motorola, Inc. 2009. All rights reserved.

568340-001-b 0409 5984 - 0K