

EVOLVING CORE NETWORKS

Motorola Softswitch Solution



The answer, widely agreed across the industry, for future core network flexibility and efficiency is the all-IP core network. Not only does this technology approach bring real cost savings versus legacy core circuit switching technology it also provides long term service capability as any service voice, data, or multimedia, can be delivered using the common IP transport, to any device, over any access network. An example of an IP based switching solution being actively deployed in the market today is the Softswitch. This is rapidly becoming the technology of choice for Service Providers implementing circuit core network investment.



Table of Content

NEW AND EXPANDING NETWORKS IN EMERGING MARKETS	3
COMPETITIVE STRATEGIES FOR LEGACY SERVICE PROVIDERS.....	3
THE NEXT STEP FORWARD—MOTOROLA SOFTSWITCH STRATEGY	4
<i>BETTER MARKET RESPONSE.....</i>	5
<i>GREATER OPERATIONAL FLEXIBILITY...5</i>	
GREATER SAVINGS.....	6
SUPERIOR RELIABILITY.....	7
FUTURE EXPANSIONISM.....	8
MOTOROLA – FUTURE PROOFING YOUR BUSINESS	8

Evolving Core Networks



NEW AND EXPANDING NETWORKS IN EMERGING MARKETS

In developing markets Service Providers rolling out new or expanding 2G/3G networks have the freedom to look at the full choice of core network strategies.

In this environment particularly when network growth is focussed on capacity expansion and lower ARPU subscriber segments the footprint efficiency and cost effectiveness will be key variables for core solution choice. The new generation of IP based Softswitches can deliver both these benefits effectively today.

COMPETITIVE STRATEGIES FOR LEGACY SERVICE PROVIDERS

In tandem with developing market opportunities to use the latest switching technologies, mature telecommunications service providers are facing a few hard truths.

In developed markets no provider has a lock on “their” services any longer. New, aggressive players are duplicating and enhancing traditional mobile services and mature providers are having to initiate new service strategies to stay competitive. In response to this expanding market subscriber expectations are also rising, and the challenge to maintain their attention and loyalty is becoming increasingly tough. Certainly the day of the “killer app” is past. For traditional service providers to sustain and grow their hard-fought positions, they will have to offer an increasing portfolio of services that are fresh, sustainable, and renewable.

The impact of this service diversity trend is particularly noticeable in core networks. Legacy mobile core networks have grown organically over the years, adding capacity and functionality as needed, until the result is sprawling complexity. However this approach needs to change if service providers are going to be able to respond to competitive incursion quickly and cost effectively. To take advantage of future revenue opportunities, network architecture must become more efficient.

Yet few can afford to simply abandon their investments in legacy core systems. One immediate answer, then, is an integrated solution that helps these networks take steps towards a fully packetised future, and it is here that Softswitch technology can play a key role. The costly and restrictive silos of

legacy networks will no longer be a factor in deploying new services and functionalities. Voice service may still be the king of the telecommunications realm, but it no longer rules alone. Increasingly, service providers must compete for subscribers by adding IP-based data and multimedia capabilities to their voice offerings. Laying those advanced capabilities over existing networks creates infrastructures that are complex to deploy and even more complex to operate. Factor in ever-shorter development and implementation lead times, constant training demands, and a never-ending need for new services and applications, and even the most capable service providers can find their network management capabilities stretched nearly to the breaking point.

THE NEXT STEP FORWARD – MOTOROLA SOFTSWITCH STRATEGY

Motorola has an extensive and proven track record of working with many equipment suppliers to create integrated, standards-based solutions for service providers. Based on that experience, we believe that one approach toward achieving the 'all packet' network architecture is a solution to packetise existing telephony services – the Softswitch. This is an advanced, innovative approach to wireless core switching that can help take networks to the next level—indeed, the next several levels—of capacity, productivity and feature availability.

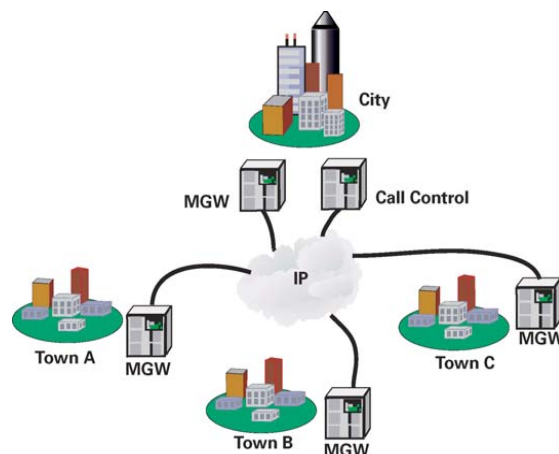

A Softswitch performs communications functions like traditional circuit switches. But unlike legacy switching solutions, the Softswitch is a flexible, open computing platform that decouples call control from bearer traffic functions. So the architecture the switch supports may be extended across wide geographical regions. The distributed architecture – 3GPP Released 4 - of the Softswitch means that service providers not only get the normal functions of a traditional switch,

such as call processing, mobility management and billing, but additionally gain the benefit to deploy core solutions in a more efficient and flexible network design with use of media gateways (MGW).

Many fixed line service providers have already deployed Softswitching to take advantage of trunk pooling and significantly reduce tandem-type costs. In the enterprise environment, Softswitches have also been deployed, and effectively deliver required feature and functionality.

BETTER MARKET RESPONSE

The Motorola GSM /UMTS Softswitch (MTS-U) is designed to meet the needs of today's service provider especially those where the lower cost and faster deployment of wireless services makes it the technology of choice.



The Motorola Softswitch approach provides significant improvements in scalability of capacity (up to 1.8 Million subscribers), supporting more than four times the amount of traffic in a significantly smaller footprint, though can scale down to support the smallest of system rollouts without all the minimum overhead of legacy systems. It can also be deployed where additional core capacity is needed without major changes to existing network architecture. Service providers in a number of countries are now using the Motorola Softswitch with the current deployed footprint delivering an overall capacity of 35 million subscribers.

GREATER OPERATIONAL FLEXIBILITY

If you are looking for a smarter way to deliver mobility services today, Motorola Softswitch delivers.

The complete solution – includes new and powerful MTS-U, MGW, HLR and OMC-3G network elements and is compliant with 3GPP standards (R99 & R4) architecture and functionality which provides a seamless migration path to next generation architectures. It supports a variety of 2G and 2.5G wireless access networks, including Gs interworking to GPRS and EDGE GSNs as well as 3G networks. It supports both GSM and UMTS technology on a single platform with same software load providing long term investment return.

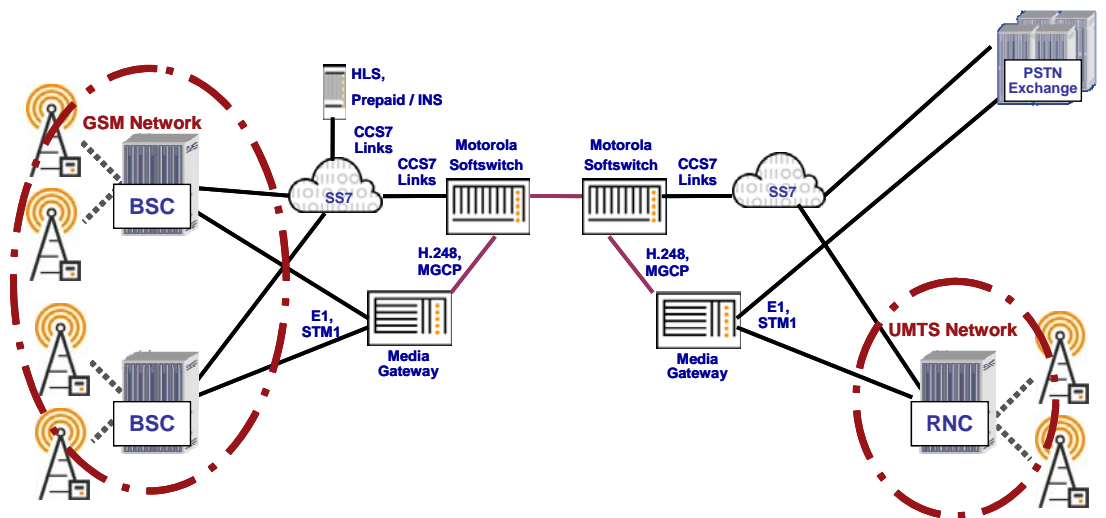

In the context of GSM the Motorola Softswitch supports new subscriber service priority features such as the enhanced Multi-level Precedence and Pre-emption (eMLPP) feature. **eMLPP** enables operators to generate extra revenue by providing premium/VIP service to subscribers. Higher priority calls can pre-empt other subscribers' lower priority calls when no resource is immediately available. Up to 7 levels of priority can be set with priority 1 supporting voice based service (VBS) calls. This feature is controlled by the priority and pre-emption indicators sent by the MTS-U to the GSM BSC.



The Motorola Softswitch solution (MTS-U, MGW, HLR platforms, USC software) has leading capacity advantage (1.8 million Visited MSC subscriber capacity), carrier level reliability and supports a technical roadmap which includes a multi-network environment.

Industry-standard open interfaces means you can select and deploy best-in-class RANs, service adjuncts and operations systems-now and in the future and Motorola Softswitch will be ready to meet your needs.

The Motorola integrated Operation and Maintenance System (OMC-3G) – simple, efficient and run on platform which itself can support several NE manager instances at a time for example; 3G UTRAN, packet switched network elements, media and charging gateways. OMC-3G supports sharing the hardware platform with the Packet Switched domain by using different software to implement various functions into the network. Over and above it provides united fault management, performance management, configuration management, network topology management, security management as well as 3GPP Northbound interfaces.

GREATER SAVINGS

Motorola Softswitch provides true lifecycle cost advantages in a numbers of ways: inbuilt high capacity, high processing capability and transmission efficiency (due to IP usage as the bearer) enables lower network-wide transmission cost.

The MTS-U requires *less than one fifth* the floor space and 60% the power consumption of legacy circuit switches. Not only that, with the bearer separated from the control, the MTS-U element of the Motorola Softswitch network can be located and managed in a centralized manner so that *operational expenditure is even lower*. Softswitch solution can be deployed relatively faster compared to conventional MSC deployment with less costly upgrades, thanks to inbuilt high capacity advantage achieved through faster processing power. This means that smaller number of switching nodes required in the network to serve larger number of subscribers. You will realize these cost advantages at the moment you switch on the system.

According to the statistics, Softswitch networks can save 20-30% of the total CAPEX compared with legacy switching networks.

SUPERIOR RELIABILITY

Motorola Softswitch delivers superior fault-tolerance and fault-avoidance, helping to ensure that the network provides carrier-grade availability.

Motorola Softswitch not only provides more functionality than traditional switching technology, it delivers the reliability that carriers expect. Softswitch is a NEBS-compliant packet-based solution, much like those already tested and



proven in existing IP-based voice/data systems. This means that Motorola's Softswitch delivers clear *improvement* in network fault tolerance over hardware-based circuit switching.

The reason is simple. A circuit failure drops calls ... period. But Motorola Softswitch software can run as separate instances on different hardware in the network system. If the first instance fails, the secondary detects the problem and instantly takes over processing. In addition Motorola's Call Admission Control provides a call-throttling mechanism to control call admission rates in the system, enabling the network to maintain operations at its engineered capacity even during extreme stress conditions. The integrity of the network is maintained without service interruption for subscribers, or service cost to the network operations.

The **Iu-Flex/A Flex** functionality provides a concept of a "POOL" of resources – that said, out of several Radio Network Controller (RNCs), Base Station Controller (BSCs) and CN network elements, each BSC/RNC can be logically routed with more than one MSC server. This gives an additional security and flexibility into the network in cases where one element in core network is faulty, the BSC will establish a connection with another core network element in order to establish a call. This feature can be deployed across all existing GSM/UMTS R99 and R4 networks.

The reliability of the network can further be enhanced by deploying **Dual homing** solution- a solution about MSC Server Disaster Tolerance. This functionality allows MGW to get connected with one MSC as an active connection and with other MSCs from MSC pool as an inactive connection. In case of active connection failure, the inactive links will be activated and the connection with other MSC will be established. As a result continuous network availability can be achieved.

At present operators still consider greater voice quality as a predominant service for their network to increase the revenue that can further be improved by savings on bandwidth. It is therefore essential that the mobile networks support mechanisms that improve quality of voice and reduces the cost on bandwidth. This can be addressed by considering **TFO/TrFo** solution.

Transcoder Free Operation (TrFO) in addition to Tandem Free Operation (TFO) concepts that eliminate the need for additional voice coding and decoding. Although the main reason for avoiding transcoding in mobile-to-mobile calls has been speech quality, the transmission of compressed information in the Core Network and Core Network to Core Network interface of the cellular network also allows mobile operators in reduction of transmission bandwidth. Therefore Transcoder Free Operation is not limited to mobile-to-mobile calls but can also be applied for calls to or from an external network.



FUTURE EXPANSION

Motorola Softswitch also allows operators to step up in future 3GPP releases by supporting the IP Multimedia Subsystem (IMS) evolution.

The Softswitch can be upgraded to MGCF (Media Gateway Control Function) function and at the same time it also provides the inter working functionality with IP IMS, UMTS, GSM, and PSTN networks, means the switch provides an investment protection as well as a smooth evolution path into an all-IP network architecture such as IMS as specified in 3GPP R5/R6.

MOTOROLA – FUTURE-PROOFING YOUR BUSINESS

Motorola Softswitch is available now as a key offering in our complete end-to-end wireless network solution, and is another demonstration of the Motorola commitment to providing intelligent products and services to today's network operator.

In developed markets, many operators are ready to replace circuit switches to enhance the network performance with greater flexibility. However with its lower cost and footprint, low energy usage, and ability to launch feature-rich services quickly, Motorola Softswitch is an opportunity to insert future capable technologies in the network today.

Motorola Softswitch is also the logical choice for network rollout or expansion in emerging markets due to its cost and space effective solution benefits versus more traditional circuit switch formats. In fact, the Motorola Softswitch is the intelligent choice whenever the ability to rapidly deploy comprehensive and value added applications—at a lower cost—can deliver critical competitive strength. And in today's wireless environment, that is virtually everywhere.

If you are ready to learn more about how Motorola's Softswitch and the rest of our full portfolio of wireless network solutions can contribute to your business success, call your Motorola representative or visit us on the web at: <http://www.motorola.com/networkoperators/>.





Motorola, Inc.

www.motorola.com/serviceproviders

MOTOROLA and the Stylized M Logo are registered in the U.S. Patent and Trademark Office. All other product or service names are the property of their registered owners. © Motorola, Inc. 2006

1006networksgms